

How do Switching Costs Affect Market Concentration and Prices in Network Industries?

Jiawei Chen*

April 12, 2011

Abstract

Consumer switching costs are inherent in most network industries, yet the role of switching costs in such industries remains largely unexplored. In this paper, I consider a dynamic model of price competition with both network effects and switching costs. I provide a series of results that characterize the effects of switching costs on market concentration and prices. These results show that the role of switching costs critically depends on the strength of the network effect and the quality of the outside option. A good understanding of these patterns will allow regulators to make informed decisions regarding public policies that alter switching costs.

1 Introduction

Consumer switching costs are inherent in most network industries, yet the role of switching costs in such industries remains largely unexplored. My paper addresses this issue by investigating the effects of switching costs on industry dynamics and market outcome (particularly market concentration and prices) in network industries.

*Department of Economics, 3151 Social Science Plaza, University of California, Irvine, CA 92697-5100. E-mail: jiaweic@uci.edu. An earlier version of this paper was circulated under the title “Switching Costs and Dynamic Price Competition in Network Industries”. I thank Dan Akerberg, Volodymyr Bilotkach, Jan Brueckner, Daniel Cerquera, Matthew Chesnes, Linda Cohen, Ulrich Doraszelski, Amihai Glazer, Hugo Hopenhayn, Yossi Spiegel, and seminar participants at CSU Long Beach, UC-Irvine, UCLA, NET Institute Conference on Network Economics 2010, IIOC 2010, and Mannheim Conference on Platform Markets 2010 for their helpful comments. I thank the NET Institute for financial support.

A product exhibits network effect if its value increases in the number of consumers who use it. A common feature of industries with network effects is the existence of finite switching costs: consumers can switch between networks but it is costly for them to do so, in terms of money and/or effort. For example, switching from one PC operating system to another requires substantial learning. Switching from one mobile phone network to another is also costly, as the consumer needs to inform her contacts of her new phone number (unless she can keep her old phone number) and may have to pay an early termination fee. Similarly, when a consumer switches from one bank to another, she needs to communicate this information to all relevant parties (direct deposits, automatic payments, etc.), which is time-consuming. In fact, according to Shy (2001, page 1), switching costs are one of the main characteristics of network industries that distinguish them from other types of industries. Despite a large literature on network effects and a large literature on switching costs, the role of switching costs in network industries remains unclear, because studies on network effects make implicit assumptions about switching costs but do not analyze their role, and studies on switching costs are conducted for non-network industries and therefore do not consider the interaction between switching costs and network effects.

Research in this area is particularly needed in light of policy makers' interests in reducing switching costs in various network industries to increase competition. In the mobile phone industry, mobile number portability (MNP), which reduces users' switching costs by enabling them to retain their phone numbers when they switch from one network to another, was implemented in many countries in recent years (for example, see ECC (2005) for the implementation in Europe and Park (2009) for the implementation in the US).¹ In the EU retail banking and payments systems markets, the European Competition Authorities Financial Services Subgroup recommends the implementation of switching facilities (objective and up-to-date comparison sites, switching services, etc.) and account number portability to lower switching costs (ECAFSS (2006)). In the software industry, various governments promote the adoption of open standards, such as Open Document Format for Office Applications (also known as OpenDocument or ODF), to avoid software vendor

¹In the mobile phone industry, carrier-specific network effects come from on-net call discounts, referred to as "tariff-mediated" network externalities in Laffont et al. (1998).

lock-in (see, for example, Casson and Ryan (2006)). In predicting the effects of policies like these, we can not just rely on past research that abstracts from network effects, because the interaction between switching costs and network effects can change the picture and make previous findings inapplicable.

Prior studies of industry dynamics with network goods make two implicit assumptions about switching costs (see, for example, Cabral (2009), Chen et al. (2009), and Dubé et al. (2010)). First, existing consumers face infinite switching costs, hence they stay with their products until the products die. Second, demand in each period comes from new consumers who do not face any switching costs.² The first assumption can be a reasonable approximation of durable network goods, as consumers make network choices infrequently: they typically re-optimize when their products die or when they are subject to some other events that prompt them to reconsider (such as changing jobs or moving to another area). It is then reasonable to model these events as exogenous shocks and label them collectively as stochastic “product deaths”. Such an assumption is more realistic than, for example, modeling consumers as making fully-informed decisions in every period.

On the other hand, the second assumption ignores an important source of firms’ demand: existing consumers who re-optimize. These consumers generally face positive but finite switching costs, and switching does occur in equilibrium. So to properly model this source of demand we need to take into account the switching costs that these consumers face.

I therefore maintain the first assumption (consumers stay with their products until the products die) but relax the second assumption to allow consumers to face switching costs when they make purchasing decisions. I develop an oligopolistic model of price competition with both network effects and switching costs. Firms dynamically optimize. A Markov perfect equilibrium is numerically solved for, and I investigate how switching costs affect market concentration and prices.

²Mitchell and Skrzypacz (2006) consider industry dynamics with non-durable network goods and model consumers as buying products in every period. They similarly assume that consumers do not face any switching costs when they buy.

1.1 Comparison with Related Studies

I find that results change significantly when we go from a setting with only switching costs to one with both network effects and switching costs, indicating that the interaction between network effects and switching costs indeed plays an important role.

Switching Costs and Market Concentration. The literature on switching costs without network effects finds that switching costs cause the larger firm to price less aggressively in order to exploit locked-in consumers. As a result, the larger firm loses consumers to the smaller firm. This is referred to as the “fat cat effect”, with the larger firm being a nonaggressive “fat cat”. This effect works against market dominance and hence markets with switching costs tend to be stable (Beggs and Klemperer (1992), Chen and Rosenthal (1996), Taylor (2003)).

When we incorporate network effects into the analysis, switching costs have a new role. They complement network effects by heightening the exit barrier for locked-in consumers and making a network size advantage longer-lasting and more valuable. As a result, firms compete more fiercely when they have comparable size, and when an asymmetry arises, the larger firm prices more aggressively in order to achieve a dominant position. This is referred to as the “top dog effect”, with the larger firm being an aggressive “top dog”. This effect facilitates tipping towards market dominance. In the presence of network effects, I find that there is a non-monotonic relationship between switching costs and market concentration. At low switching costs, the top dog effect dominates and an increase in switching costs can give rise to market dominance. But at high switching costs, the fat cat effect takes over and an increase in switching costs can lead to market fragmentation.

Switching Costs and Prices. Regarding the effects of switching costs on prices, the traditional view in the theoretical literature is that firms’ incentive to charge higher prices in order to exploit locked-in consumers (the “harvesting incentive”) dominates their incentive to charge lower prices in order to build a larger customer base (the “investment incentive”), and hence switching costs increase equilibrium prices (Beggs and Klemperer (1992), To (1996)). However, several recent theoretical studies find that equilibrium prices can be decreasing in switching costs (Doganoglu and Grzybowski (2005), Doganoglu (2005),

Cabral (2008), Arie and Grieco (2010)).³ Similar to the disagreement in the theoretical literature, empirical studies on this subject also reach conflicting findings (Viard (2007) and Park (2009) find a positive relation between switching costs and prices for 800-number service and mobile phone service, respectively, whereas Dubé et al. (2009) find a negative relation for refrigerated orange juice and margarine).

The results from my model offer a new perspective on the above “price puzzle of switching costs”, by showing that both scenarios (“prices increase in switching costs” and “prices decrease in switching costs”) can arise as equilibrium outcomes and that network effects and competition from the outside option are key determinants. Specifically, I find that if the outside option is fairly inferior, the average price increases in switching costs, consistent with the findings in the traditional theoretical literature. But if there exists a viable outside option, the average price decreases in switching costs when the network effect is weak but increases in switching costs when the network effect is strong.

Existing empirical studies provide anecdotal evidence that supports the predictions from my model. In particular, Dubé et al. (2009) study the markets for refrigerated orange juice and margarine and their counterfactuals show that prices decrease with switching costs. In contrast, Park (2009) studies the mobile phone industry and finds that the introduction of number portability caused prices to decrease, implying that switching costs lead to higher prices. It is likely that the mobile phone industry has a stronger network effect and a weaker outside option than the markets for refrigerated orange juice and margarine, hence the findings in these studies support the notion that prices tend to rise in the switching cost when the network effect is strong and the outside option is weak.

Analyzing Network Effects and Switching Costs Jointly. For a recent survey of both the literature on switching costs and the literature on network effects, see Farrell and Klemperer (2007); see also Klemperer (1995) and Economides (1996). To my knowledge, only two prior papers explicitly consider network effects and switching costs jointly. Doganoglu and Grzybowski (2005) use a two-period differentiated-products duopoly model

³Different from my setting, Doganoglu and Grzybowski (2005) use a two-period model and assume a fixed market size, Doganoglu (2005) considers experience goods and a linear quadratic specification, Cabral (2008) assumes that sellers are able to discriminate between locked-in and not locked-in consumers, and Arie and Grieco (2010) consider non-network goods.

to study the effects of switching costs and network effects on demand elasticities and prices. Suleymanova and Wey (2008) use a Bertrand duopoly model with myopic firms and consumers to study the market outcome under network effects and switching costs, and find that market dynamics critically depend on the ratio of switching costs to network effects.

There are two main differences between my paper and the above two papers. First, I work with an infinite-horizon model, which avoids the end-of-game effects in the last period and allows me to investigate both the short-run and the long-run industry dynamics. For example, in the presence of switching costs, in an infinite-horizon model firms have both the “investment incentive” and the “harvesting incentive” in every period, whereas in a two-period model they do not. Second, I endogenize the market size by modeling an outside option. This feature enables me to analyze the competition for switching consumers in both types of scenarios: within a mature and saturated market, as well as when new technologies or platforms are being adopted. The modeling of an outside option is particularly needed in the latter case, as the use of old technologies, or simply “doing without”, is a common choice around early adoption. Moreover, the results from my model indicate that the quality of the outside option is an important determinant of the effects of switching costs and hence need to be taken into account.

The next section describes the model. Section 3 reviews Markov perfect equilibria of the model. Section 4 examines the effects of switching costs on firms’ expected sales. Section 5 presents the results on market concentration. Section 6 presents the results on prices. Section 7 concludes.

2 Model

This section describes a dynamic model of price competition with both network effects and switching costs. The model builds on Chen et al. (2009) and adds switching costs. Since the objective is to provide some general insights about the effects of switching costs in network industries, the model is not tailored to a particular industry. Instead, a more generic model is developed to capture the key features of many markets characterized by network effects and switching costs.

2.1 State Space

The model is cast in discrete time with an infinite horizon. There are $N \geq 2$ single-product price-setting firms, who sell to a sequence of buyers with unit demands. Firms' products are durable subject to stochastic death. They are referred to as the inside goods. There is also an outside option ("no purchase"), indexed 0. At the beginning of a period, a firm is endowed with an installed base which represents users of its product. Let $b_i \in \{0, 1, \dots, M\}$ denote the installed base of firm i where M is the bound on the sum of the firms' installed bases. $b_0 = M - b_1 - \dots - b_N$ is taken as the outside option's "installed base", though it does not offer network benefits. The industry state is $b = (b_1, \dots, b_N)$, with state space $\Omega = \{(b_1, \dots, b_N) | 0 \leq b_i \leq M, i = 1, \dots, N; b_1 + \dots + b_N \leq M\}$.

2.2 Demand

Demand in each period comes from a random consumer who chooses one of the $N + 1$ goods. Let $r \in \{0, 1, \dots, N\}$ denote the good that she is loyal to.⁴ Let r be distributed $\Pr(r = j | b) = b_j / M, j = 0, 1, \dots, N$, so that a larger installed base implies a larger expected demand from loyal consumers. The utility that a consumer loyal to good r gets from buying good i is

$$\begin{aligned} u_{ri} &= v_i + \mathbf{1}(i \neq 0)\theta g(b_i) - p_i - \mathbf{1}(r \neq 0, i \neq 0, i \neq r)k + \epsilon_i \\ &= \bar{u}_{ri} + \epsilon_i \end{aligned}$$

Here v_i is the intrinsic product quality, which is fixed over time and is common across firms: $v_i = v, i = 1, \dots, N$. Since the intrinsic quality parameters affect demand only through the expression $v - v_0$, without loss of generality I set $v = 0$, but consider different values for v_0 .

The increasing function $\theta g(\cdot)$ captures network effects, where $\theta \geq 0$ is the parameter

⁴A consumer may be loyal to a firm's product because she previously used that product and now her product dies and she returns to the market. A consumer may also be loyal to a firm's product because of her relationship with current users. For example, if a consumer is familiar with a particular product because her relatives, friends, or colleagues are users of this product, then she may be loyal to this product even if she has never purchased from this market before. In both cases, it is a reasonable approximation to model the number of loyal consumers as proportional to the size of the installed base.

controlling the strength of network effect. There are no network effects associated with the outside option. The results reported below are based on linear network effects, that is, $g(b_i) = b_i/M$. I have also allowed g to be convex, concave, and S-shaped, and the main results are robust.

p_i denotes the price for good i . The price of the outside option, p_0 , is always zero.

The nonnegative constant k denotes switching cost, and is incurred if the consumer switches from one inside good to another. A consumer who switches from the outside option to an inside good incurs a start-up cost, which is normalized to 0. Increasing the start-up cost above 0 has the effect of lowering the inside goods' intrinsic quality relative to that of the outside option.

ϵ_i is the consumer's idiosyncratic preference shock, and \bar{u}_{ri} is the utility excluding ϵ_i . ($\epsilon_0, \epsilon_1, \dots, \epsilon_N$) and r are unknown to the firms when they set prices.

The consumer buys the good that offers the highest current utility. I am then assuming that consumers make myopic decisions. Such a parsimonious specification of consumers' decision-making allows rich modeling of firms' prices and industry dynamics. Allowing consumers to be forward-looking with rational expectations in the presence of both network effects and switching costs is an important but challenging extension of the current work.

Assume ϵ_i , $i = 0, 1, \dots, N$ is distributed type I extreme value, independent across products, consumers, and time. The probability that a consumer who is loyal to good r buys good i is then

$$\phi_{ri}(b, p) = \frac{\exp(\bar{u}_{ri})}{\sum_{j=0}^N \exp(\bar{u}_{rj})}, \quad (1)$$

where b is the vector of installed bases and p is the vector of prices.

Remark. The existing literature on network industries assume that the consumers who make purchasing decisions are always "new", in the sense that they do not face any switching costs. In the current model, these consumers can be new or loyal to one of the firms. This new modeling captures the idea that the networks compete for not only new consumers but also partially locked-in consumers, and allows me to directly assess the role of switching costs in network industries. ■

2.3 Depreciation and Transition

In each period, each unit of a firm's installed base independently depreciates with probability $\delta \in [0, 1]$, for example due to product death. Thus the expected size of the depreciation to a firm's installed base is proportional to the size of its installed base. Let $\Delta(x|b_i)$ denote the probability that firm i 's installed base depreciates by x units. We have

$$\Delta(x|b_i) = \binom{b_i}{x} \delta^x (1 - \delta)^{b_i - x}, \quad x = 0, \dots, b_i, \quad (2)$$

since x is distributed binomial with parameters (b_i, δ) .

Let $q_i \in \{0, 1\}$ indicate whether or not firm i makes the sale. Firm i 's installed base changes according to the transition function

$$\Pr(b'_i|b_i, q_i) = \Delta(b_i + q_i - b'_i|b_i), \quad b'_i = q_i, \dots, b_i + q_i. \quad (3)$$

If the joint outcome of the depreciation and the sale results in an industry state outside of the state space, the probability that would be assigned to that state is given to the nearest state(s) on the boundary of the state space.

2.4 Timing of the Model

At the beginning of a period, the firms are endowed with installed bases $b = (b_1, \dots, b_N)$. Depreciation then takes place according to Eq. (2). Next the firms set prices without knowing the decision-making consumer's idiosyncratic preference shocks and the good that she is loyal to (though the firms do know the probability distributions for both). The consumer then chooses one of the $N + 1$ goods, based on (1) the installed bases before the depreciation, (2) the firms' prices, (3) the realization of her idiosyncratic preference shocks, and (4) the realization of the good that she is loyal to. Lastly the next-period state b' is determined according to the transition function Eq. (3).

Note that when the consumer makes her choice, the network effects are based on the installed bases at the beginning of the period, that is, before the depreciation and before this consumer is added to any of the networks. One interpretation is that network effects appear

with a lag, as is the case with software applications, video game titles, etc. A lag is created when a network good leads to the creation over time of a complementary stock (using the terminology of Llobet and Manove (2006)) that increases the value of the network. For example, a computer operating system induces the development of a complementary stock of software applications, and since the development of software applications takes time, the size of the complementary stock is proportional to the size of the installed base with a lag.

2.5 Bellman Equation and Strategies

Let $V_i(b)$ denote the expected net present value of future cash flows to firm i in state b . Firm i 's Bellman equation is

$$V_i(b) = \max_{p_i} E_r \left[\phi_{ri}(b, p_i, p_{-i}(b))p_i + \beta \sum_{j=0}^N \phi_{rj}(b, p_i, p_{-i}(b))\bar{V}_{ij}(b) \right], \quad (4)$$

where $p_{-i}(b)$ are the prices charged by firm i 's rivals in equilibrium (given the installed bases), the (constant) marginal cost of production is normalized to zero, $\beta \in [0, 1)$ is the discount factor, and $\bar{V}_{ij}(b)$ is the expected continuation value to firm i given that firm j wins the current consumer:

$$\bar{V}_{ij}(b) = \sum_{b'} \Pr(b'|b, q_j = 1)V_i'(b').$$

Differentiating the right-hand side of Eq. (4) with respect to p_i and using the properties of logit demand yields the first-order condition⁵

$$E_r \left[-\phi_{ri}(1 - \phi_{ri})(p_i + \beta\bar{V}_{ii}) + \phi_{ri} + \beta\phi_{ri} \sum_{j \neq i} \phi_{rj}\bar{V}_{ij} \right] = 0. \quad (5)$$

The pricing strategies $p(b)$ are the solution to the system of first-order conditions.

⁵See the Appendix for the derivation of the first-order condition.

2.6 Equilibrium

I focus attention on symmetric Markov perfect equilibria (MPE), where symmetry means agents with identical states are required to behave identically. For example, if there are two firms, then symmetry means firm 2's price in state $(b_1, b_2) = (\widehat{b}, \widetilde{b})$ is identical to firm 1's price in state $(b_1, b_2) = (\widetilde{b}, \widehat{b})$, and similarly for the value function. I therefore define $p(b_1, b_2) \equiv p_1(b_1, b_2)$ and $V(b_1, b_2) \equiv V_1(b_1, b_2)$, and note that $p_2(b_1 = \widehat{b}, b_2 = \widetilde{b}) = p(\widetilde{b}, \widehat{b})$ and $V_2(b_1 = \widehat{b}, b_2 = \widetilde{b}) = V(\widetilde{b}, \widehat{b})$.

I restrict attention to pure strategies, which follows the majority of the literature on numerically solving dynamic stochastic games (Pakes and McGuire (1994), Pakes and McGuire (2001)). A symmetric MPE in pure strategies always exists (Doraszelski and Satterthwaite (2010)), but as is true with many other dynamic models, there may exist multiple MPE. I therefore take a widely used selection rule in the dynamic games literature by computing the limit of a finite-horizon game as the horizon grows to infinity (for details see Chen et al. (2009)). With this equilibrium selection rule in place, the iterative algorithm always converged and resulted in a unique MPE.

2.7 Parameterization

The key parameters of the model are the strength of network effect θ , the switching cost k , the rate of depreciation δ , and the quality of the outside option v_0 . I focus on two values for v_0 , $-\infty$ (fixed market size) and 0 (endogenous market size), but also consider some in-between values. The lower bound for δ is zero and corresponds to the unrealistic case in which installed bases never depreciate. On the other hand, if δ is sufficiently high then the industry never takes off. I consider many values for δ between 0 and 0.2. I investigate the following values for the strength of network effect and the switching cost: $\theta \in \{0, 0.2, \dots, 4\}$, and $k \in \{0, 0.2, \dots, 3\}$. While I extensively vary the key parameters, I hold the remaining parameters constant at $N = 2$, $M = 20$, and $\beta = \frac{1}{1.05}$, which corresponds to a yearly interest rate of 5%.

While the model is not intended to fit any specific product, the own-price elasticities for the parameterizations that I consider are reasonable compared with findings in empirical studies. As representative examples of the equilibria in the model, the own-price elasticities

for the parameterizations in Figures 1 and 2 are -0.62 and -0.75 , respectively. These numbers are in line with the own-price elasticities in Gandal et al. (2000) (-0.54 for CD players, computed according to results reported in the paper), Dranove and Gandal (2003) (-1.20 for DVD players), and Clements and Ohashi (2005) (ranging from -2.15 to -0.18 for video game consoles).

3 Dynamic Equilibrium

Depending on the parameter values, three qualitatively distinct policy functions are found. They are referred to as Rising, Tipping, and Peaked.

A *Rising* equilibrium is characterized by a relatively monotonic policy function, in which price increases in a firm’s own base and is insensitive to the rival’s base. The industry spends most of the time in symmetric states. This equilibrium occurs when both network effect and switching cost are weak.⁶

With non-trivial network effect and/or switching cost, two types of equilibria dominate: Tipping and Peaked. These equilibria are the most insightful for learning about dynamic competition and the role of switching costs, and will be the focus of our attention.

3.1 Tipping Equilibrium

In a *Tipping* equilibrium, there is intense price competition when firms’ installed bases are of comparable size, and the industry spends most of the time in asymmetric states. A Tipping equilibrium occurs when the network effect is strong and depreciation is modest. This equilibrium is also found in prior dynamic models with increasing returns, such as Doraszelski and Markovich (2007), Chen et al. (2009), and Besanko et al. (2010).

An example of a Tipping equilibrium is shown in Figure 1. The policy function features a deep trench along and around the diagonal (Panel 1). When the industry is sufficiently away from the diagonal, price is relatively high. The value function (Panel 2) shows that the larger firm enjoys a much higher value than the smaller firm. It is the substantial difference

⁶When both network effect and switching cost are 0, the model degenerates to a static one and the price function is flat.

between the leader's and the follower's values that drives the intense price competition in symmetric states. Each firm prices aggressively in hope of getting an installed base advantage and eventually achieving a dominant position; hence the deep trench along and around the diagonal in the policy function.

When the industry is sufficiently away from the diagonal, the smaller firm gives up the fight by not pricing aggressively, and accepts having a low market share. If instead it were to price aggressively and try to overtake the larger firm, it would have to price at a substantial discount for an extended period of time. Anticipating that such an aggressive strategy is not profitable, the smaller firm abandons the fight, ensuring that the larger firm enjoys a dominant position and high profits.

To show the evolution of the industry structure over time, Panels 3 and 4 plot the 15-period transient distribution of installed bases (which gives the frequency with which the industry state takes a particular value after 15 periods, starting from state $(0, 0)$ in period 0) and the limiting distribution (which gives the frequency with which the state takes a particular value as the number of periods approaches infinity), respectively. Both the transient distribution and the limiting distribution have modes that are highly asymmetric. They show that over time the industry state moves towards asymmetric outcomes, and that market dominance is likely.

Panel 5 plots the probability that a firm makes a sale. The larger firm enjoys a significant advantage: the average probability that firm 1 makes a sale is 0.71 in states with $b_1 \geq b_2$, compared to an average probability of 0.29 in states with $b_1 \leq b_2$.

Panel 6 plots the resultant forces, which report the expected movement of the state from one period to the next (for visibility of the arrows, the lengths of all arrows are normalized to 1, therefore only the direction, not the magnitude, of the expected movement is reported). The advantage enjoyed by the larger firm in terms of the sale probability pulls the industry away from the diagonal once a small asymmetry arises. Such dynamics are responsible for the tipping of the market that leads to asymmetric outcomes in the long run.

Result 1 (Tipping Equilibrium). *When the network effect is strong and depreciation is modest, equilibrium is characterized by intense price competition when firms have comparable installed bases, and tipping towards market dominance when an asymmetry emerges.*

When there exists a viable outside option, there is a variant to Tipping equilibrium. In this variant, referred to as *Mild Tipping* equilibrium, the modes of the limiting distribution are still highly asymmetric but a fair amount of mass is spread over the states between the two modes. With a viable outside option, the payoff to having a dominant position is reduced, because the outside option serves as a non-strategic player and restrains the dominant firm’s ability to exploit its locked-in consumers. Consequently, in a Mild Tipping equilibrium, firms do not fight so fiercely for dominance when they are of comparable size, and the tendency for the industry to move towards asymmetric states is weaker than in a Tipping equilibrium. Details about the Mild Tipping equilibrium are provided in the Appendix.

3.2 Peaked Equilibrium

There is another type of equilibrium which is new to the dynamic oligopoly literature and arises solely because firms also compete for existing consumers facing switching costs. A *Peaked* equilibrium is characterized by a peak in the policy function when each firm has half of the consumer population in its installed base. Away from this peak, price drops rapidly for the smaller firm and mildly for the larger firm. The industry spends most of the time in relatively symmetric states and market dominance is unlikely. A Peaked equilibrium occurs when the switching cost is strong and the outside option is fairly inferior.

An example of a Peaked equilibrium is shown in Figure 2 (the only change in the parameterization from Figure 1 to Figure 2 is that k is increased from 1 to 2). When each firm locks in half of the consumer population, price competition is weak as reflected in the peak in the policy function (Panel 1). Due to switching costs, both firms have strong incentives to charge high prices to “harvest” their large bases of locked-in consumers. Moreover, the absence of unattached consumers (consumers who are not loyal to either of the firms) weakens firms’ “investment” incentive to lower prices. Off of the peak, the smaller firm drops its price substantially in order to increase expected sales and move the industry back to the peak. The larger firm also drops its price mildly, which is a response to the smaller firm’s aggressive pricing rather than an effort to achieve market dominance.

The value function (Panel 2) also has a peak when each firm locks in half of the consumer

population. Off of the peak, the smaller firm’s value drops rapidly. The larger firm’s value also drops slightly, because the smaller firm starts to price aggressively and the larger firm has to respond by cutting its own price. Since firms have little incentive to induce tipping in their favor, market dominance is unlikely, as reflected in the unimodal transient distribution and limiting distribution (Panels 3 and 4, respectively).

Panel 5 shows that in states that are reasonably symmetric, it is the smaller firm who has a higher probability of sale. This pattern results from the smaller firm’s aggressive pricing aimed at bringing the industry back to the peak. In Panel 6, the resultant forces show global convergence towards the symmetric modal state.

The occurrence of a Peaked equilibrium requires strong switching cost and the absence of a viable outside option. A key function of switching costs is that they segment the market into submarkets, each containing consumers who have previously purchased from a particular firm. A Peaked equilibrium is based on such market segmentation, which allows firms to price in a fashion that resembles collusion even in a noncooperative equilibrium (see Klemperer (1987)). However, if the outside option is viable, then it constitutes a non-strategic player and restrains firms’ ability to exploit the locked-in consumers, weakening the basis for firms to engage in collusion-like pricing. In fact, with $v_0 = 0$ a Peaked equilibrium never occurs. We further investigate the role of the outside option in the next section.

Result 2 (Peaked Equilibrium). *When the switching cost is strong and the outside option is fairly inferior, equilibrium is characterized by a peak in the prices when each firm locks in half of the consumer population, and an absence of market dominance.*

Remark. The Peaked equilibrium identified above is new to the dynamic oligopoly literature, and is consistent with some real-world examples. For instance, Barla (2000) finds that in the U.S. domestic airline industry (with switching costs due to frequent-flyer programs), prices are higher when firms have symmetric market shares. While the hypothesis in the theoretical literature has been that symmetry among firms facilitates collusion (for example, Compte et al. (2002) and Vasconcelos (2005)), the Peaked equilibrium suggests a new possibility, in which switching costs and the lack of a viable outside option induce firms in a *noncooperative* equilibrium to heighten prices when the market is evenly segmented. ■

3.3 Industry Dynamics

The current model allows us to study strategic interactions between endogenously asymmetric firms in a general dynamic setting. Below we examine how the industry structure and the firms' strategic choices evolve over time, focusing on the contrast between Tipping equilibrium and Peaked equilibrium.

The left column of Figure 3 depicts a Tipping equilibrium $((v_0, \delta, \theta, k) = (-\infty, 0.06, 2.2, 1))$. From top to bottom, the four panels plot the evolution of the firms' installed bases, prices, probabilities of sale, and profits, respectively, from period 0 to period 100, starting from state $(0, 0)$ in period 0. The solid lines show the expectation (based on transient distributions) of the variables for the larger firm, and the dashed lines show those for the smaller firm. The right column plots the same for a Peaked equilibrium $((v_0, \delta, \theta, k) = (-\infty, 0.06, 2.2, 2))$. For the purpose of comparison, the scale and location of the y -axis are the same for panels in the same row.

The two columns exemplify the distinction between Tipping equilibrium and Peaked equilibrium in terms of firms' endogenous asymmetry and strategic interactions over time. In Tipping equilibrium, the difference in firms' installed bases widens quickly, reaching 4.6 by period 10 and stabilizing at 7.4 in the long run (Panel 1). In contrast, in Peaked equilibrium, the difference in firms' installed bases grows slowly over time and remains below 2.9 throughout (Panel 2). In the long run, the larger firm's base is larger than the smaller firm's by 169% in Tipping equilibrium, but by only 43% in Peaked equilibrium, indicating that the tendency towards market dominance is much stronger in Tipping equilibrium.

Turning to firms' pricing decisions, we see that in Tipping Equilibrium (Panel 3), at the beginning of the race the firms fiercely fight for future dominance by charging negative prices. When a firm pulls ahead, both firms increase their prices substantially. The larger firm keeps its price below its rival's until period 25 (in which the base differential reaches 6.5). Afterwards the larger firm's price is slightly higher than the smaller firm's, but the price differential is never larger than 0.17. On the other hand, in Peaked equilibrium (Panel 4), the firms' prices start at about 1 and increase over time. The larger firm's price is always higher than the smaller firm's, and the price differential gradually widens until it stabilizes at 0.93, much larger than the price differential in Tipping equilibrium. Furthermore, both

firms' prices are much higher in the Peaked equilibrium than in the Tipping equilibrium.

Next we consider firms' probabilities of sale. In Tipping equilibrium (Panel 5), the larger firm enjoys a much larger probability of sale throughout, and in the long run, the larger firm makes a sale with probability 0.71, compared to only 0.29 for the smaller firm. This is in sharp contrast to Peaked equilibrium (Panel 6). There, the two firms' probabilities of sale are never more than 0.06 apart. The larger firm holds a slight lead initially, but the smaller firm is on top afterwards. This pattern is a result of the market segmentation created by switching costs, which induces the firms to share the market and exploit their locked-in consumers and discourages the larger firm from pricing aggressively for market dominance.

As for profits, in Tipping equilibrium (Panel 7), we see that both firms have negative profits at the beginning of the race as they fight for future dominance. When the race is over, the larger firm enjoys a much higher profit than the smaller firm (the larger firm's long-run profit is 1.10, compared to 0.39 for the smaller firm). In contrast, in Peaked equilibrium (Panel 8), each firm's profit starts at about 0.5 and gradually increases. The larger firm always leads in profit, but not by much (the larger firm's long-run profit is 1.43, compared to 1.12 for the smaller firm).

The only difference between the parameterizations in the two columns in Figure 3 is an increase in the switching cost from $k = 1$ in the left column to $k = 2$ in the right column. Therefore, the contrast described above is an example of switching costs' ability to drastically alter industry dynamics. Here an increase in switching costs suppresses the race for dominance that is characteristic of network industries and turns it into a "peaceful" sharing of the market by two firms focused on harvesting their own locked-in consumers.

4 Switching Costs in Network Industries: A Taxonomy of Effects

In this section, we investigate how switching costs affect firm's expected sales in network industries, which forms the basis for our later analysis of how switching costs affect market concentration and prices. In any given state, if the larger firm has a larger expected sale

that more than compensates for its larger expected depreciation, then in expectation the asymmetry in the firms' installed bases will grow, and there is increasing dominance in that state; and vice versa.

Firms' expected sales are determined by consumers' product choices, which depend on both switching costs and firms' prices (as is evident from Eq. (1)). Therefore, an increase in switching costs affects firms' expected sales through two channels. In the direct channel, holding firms' prices fixed, an increase in switching costs makes a consumer more likely to buy the product that she is loyal to. In the indirect channel, an increase in switching costs leads to changes in firms' prices, which in turn affect consumers' choices.

4.1 Direct Channel and Indirect Channel

Consider a permanent increase in the switching cost k . Such an increase implies that both the current-period switching cost (denoted by k^c) and the switching cost in all future periods (denoted by k^f) are increased. At a given state, let $\phi = (\phi_1, \phi_2) = (E_r[\phi_{r1}], E_r[\phi_{r2}])$ denote the firms' expected sales. ϕ depends on firms' equilibrium prices $p = (p_1, p_2)$ and k^c . p , in turn, depends on k^c and firms' future value function, which we denote by the $(M + 1) \times (M + 1)$ matrix V' (such dependence can be seen by examining the first order condition, Eq. (5), in which ϕ_r depends on k^c , and \bar{V}_i depends on V').⁷ Furthermore, note that k^f affects V' , and therefore it affects p through its impact on V' .

We are interested in $d\phi/dk$, which tells how a permanent increase in the switching cost affects the firms' expected sales. Since p depends on k^c and V' , and since V' depends on k^f , we can rewrite firms' equilibrium prices as $p(k^c, V'(k^f))$, to highlight such dependence. Correspondingly, the expected sales ϕ can be written as $\phi(p(k^c, V'(k^f)), k^c)$. We now totally

⁷The (i, j) -th element of the matrix V' is firm 1's future value associated with the next-period state $(b'_1 = i - 1, b'_2 = j - 1)$. Since any (b'_1, b'_2) such that $b'_1 + b'_2 > M$ is not part of the state space, any (i, j) -th element in V' such that $(i - 1) + (j - 1) > M$ does not enter into our analysis and can simply be fixed at 0 throughout.

differentiate ϕ with respect to k :⁸

$$\begin{aligned}
\frac{d\phi}{dk} &= \frac{d\phi}{dk^c} \Big|_{dk^f=0} \frac{dk^c}{dk} + \frac{d\phi}{dk^f} \Big|_{dk^c=0} \frac{dk^f}{dk} \\
&= \left(\frac{\partial\phi}{\partial k^c} + \frac{\partial\phi}{\partial p} \frac{\partial p}{\partial k^c} \right) \times 1 + \left(\frac{\partial\phi}{\partial p} \frac{\partial p}{\partial V'} \frac{dV'}{dk^f} \right) \times 1 \\
&= \underbrace{\frac{\partial\phi}{\partial k^c}}_{\substack{2 \times 1 \\ \text{direct channel}}} + \underbrace{\frac{\partial\phi}{\partial p} \left(\frac{\partial p}{\partial k^c} + \frac{\partial p}{\partial V'} \frac{dV'}{dk^f} \right)}_{\substack{2 \times 2 \quad 2 \times 1 \quad 2 \times (M+1)^2 (M+1)^2 \times 1 \\ \text{indirect channel}}}. \tag{6}
\end{aligned}$$

The above equation makes it clear that k^c affects ϕ through both the direct channel (which takes p as *fixed*) and the indirect channel (which goes through changes in p), whereas k^f affects ϕ only through the indirect channel (which goes through V' and then p). Before we look at the overall effects of switching costs on the equilibrium market outcome in Sections 5 and 6, we first decompose these effects according to the direct channel and the indirect channel, to clarify the intuition.

4.2 Direct Channel: Network Solidification Effect and Market Contraction Effect

In this subsection we examine the changes in firms' expected sales and industry dynamics brought about by switching costs through the direct channel, represented by $\partial\phi/\partial k^c$ in Eq. (6).

In the direct channel, an increase in switching costs heightens the “exit barrier” for locked-in consumers and solidifies existing networks. Everything else being equal, higher switching costs make consumers in the installed base less likely to switch to rival products. Consequently, an installed base advantage becomes better protected. We refer to this effect as the *network solidification effect* of switching costs. To the extent that there was reversion to the mean (the opposite of increasing dominance) and the larger firm was losing consumers to the smaller firm prior to the increase in k^c , the network solidification effect benefits the larger firm by slowing down the process of such reversion to the mean. To examine this

⁸In the terminology of Chiang and Wainwright (2005, page 192), $\frac{d\phi}{dk^c} \Big|_{dk^f=0}$ and $\frac{d\phi}{dk^f} \Big|_{dk^c=0}$ in the equation below are the “partial total derivatives”.

effect, we consider the discrete analogue of $\partial\phi/\partial k^c$ by marginally increasing k^c from k^0 to $k^0 + 0.01$ while holding firms' policy functions fixed at the ones from $k = k^0$. The resulting changes in the firms' expected sales, $(\Delta\phi_1, \Delta\phi_2)$, is a vector that tells the change in the resultant forces.

The left column of panels in Figure 4 reports for a Peaked equilibrium. Panel 1 shows the relative change in firm 1's expected sale.⁹ The panel shows that as a result of the marginal increase in k^c , the smaller firm's expected sale decreases, whereas the larger firm's expected sale increases. For the same parameterization, Panel 4 reports the changes in the resultant forces due to the changes in the expected sales. It shows that the marginal increase in k^c leads to *asymmetry movements* of the industry state, that is, movements parallel to the $(0, 20) - (20, 0)$ diagonal and in the direction of increasing asymmetry between the two firms. In addition, Panel 7 reports the corresponding changes in the limiting distribution, where a "+" symbol in a state indicates an increase in the probability of that state, and a "-" symbol indicates a decrease in the probability. This panel shows that as a result of the marginal increase in k^c , the industry spends less time in relatively symmetric states and more time in asymmetric states. Thus both Panel 4 and Panel 7 show an increased tendency for the industry structure to become asymmetric.

The center column in Figure 4 reports for a Tipping equilibrium. These panels show that the network solidification effect generally causes asymmetry movements of the state, with one exception. The only area in which the network solidification effect may cause *symmetry movements* of the state (movements parallel to the $(0, 20) - (20, 0)$ diagonal and in the direction of increasing symmetry between the two firms) is between the two modal states in a Tipping equilibrium, where the smaller firm was rapidly losing consumers to the larger firm prior to the increase in k^c . But even in such a case, the asymmetry movements still dominate and the overall impact of a marginal increase in k^c is still an increased tendency towards asymmetry. In fact, for the Tipping equilibrium in the center column in Figure 4, the marginal increase in k^c results in an increase of the expected Herfindahl-Hirschman Index (HHI; based on installed bases and weighted by probabilities in the limiting distribution),

⁹Due to symmetry, the change in firm 2's expected sale in state $(\widehat{b}, \widetilde{b})$ is equal to the change in firm 1's expected sale in state $(\widetilde{b}, \widehat{b})$. This also applies to the changes in equilibrium price, expected sale, and future value function presented in the subsequent figures.

despite causing symmetry movements between the two modal states. More generally, I find that in all the parameterizations with $v_0 \in \{-\infty, 0\}$, $\delta \in \{0, 0.01, \dots, 0.2\}$, $\theta \in \{0, 0.2, \dots, 4\}$, $k \in \{0, 0.2, \dots, 3\}$, a marginal increase in k^c always causes the expected HHI to increase.

We now turn to the case in which there exists an outside option so that the market size is endogenous. The right column in Figure 4 reports for a Mild Tipping equilibrium. We see an important difference brought about by the outside option. While in Panels 4 and 5 (without a viable outside option) all arrows are parallel to the $(0, 20) - (20, 0)$ diagonal, arrows in Panel 6 (with a viable outside option) point towards larger asymmetry and smaller market size ($b_1 + b_2$). Therefore, the changes in the resultant forces in Panel 6 are the combination of two types of movements of the industry state: asymmetry movements (as described above) and *contraction movements* (movements parallel to the $(0, 0) - (20, 20)$ diagonal and in the direction of decreasing market size). Thus Panel 6 illustrates that when there exists an outside option, an increase in switching costs also has a *market contraction effect*. Whereas the network solidification effect corresponds to a shift of the demand from one inside good to the other, the market contraction effect corresponds to a shift of the demand from the inside goods to the outside option, which arises because the increase in switching costs makes the inside goods less attractive relative to the outside option. The reduction in market size is reflected in Panel 9. In contrast to Panels 7 and 8, Panel 9 shows increased probabilities assigned to states that are close to the origin, in addition to states that are highly asymmetric. More generally, I find that in all the parameterizations with $v_0 = 0$ and $\delta > 0$, a marginal increase in k^c always causes the expected market size (weighted by probabilities in the limiting distribution) to decrease.

Result 3 (Direct Channel). *An increase in the current-period switching cost affects firms' expected sales directly: the network solidification effect tends to move the industry towards asymmetric states, and when there exists a viable outside option, the market contraction effect shrinks the size of the market.*

4.3 Indirect Channel: Fat Cat Effect and Top Dog Effect

The literature on switching costs without network effects finds that markets with switching costs tend to be stable: switching costs cause the larger firm to price less aggressively (in

order to harvest locked-in consumers) and lose consumers to the smaller firm, and therefore asymmetries in market shares are dampened over time (Beggs and Klemperer (1992), Chen and Rosenthal (1996), Taylor (2003)). This is referred to as the *fat cat effect*, with the larger firm being a nonaggressive “fat cat”.¹⁰

In markets with network effects, switching costs have another effect on firms’ prices and the tendency towards market dominance. First note that a basic property of network effects is that they can tip the market to one firm as soon as it has an installed base advantage. However, for a firm to price aggressively and give up current profit, the prospect of future dominance by investing in its installed base must be sufficiently great, which requires that network effects are sufficiently strong and that the installed base does not depreciate too rapidly in the future. This is where switching costs come into play: just as an increase in the current-period switching cost k^c solidifies the current networks (the network solidification effect discussed above), an increase in the future switching cost k^f solidifies networks in the future, making an installed base advantage longer-lasting and more valuable. This effect intensifies price competition when firms’ installed bases are of comparable size, and when an installed base differential emerges, this effect causes the larger firm to price more aggressively in order to build on its advantage (since the prospect of future dominance becomes better and the reward becomes greater). We refer to this effect as the *top dog effect* of switching costs, with the larger firm being an aggressive “top dog”. This top dog effect of switching costs complements network effects and makes market dominance more likely.

Fat Cat Effect. To examine the fat cat effect, we consider the discrete analogue of $\partial p/\partial k^c$ by marginally increasing the current-period switching cost k^c from k^0 to $k^0 + 0.01$ while holding the future switching cost k^f fixed at k^0 .

When there is an increase in k^c , the harvesting incentive to raise price is stronger for the larger firm, because a majority of the loyal demand comes from consumers loyal to its product, and now these consumers find it more difficult to switch. Furthermore, the incentive to lower price is stronger for the smaller firm, because a majority of the loyal

¹⁰The terms “fat cat effect” and “top dog strategy” are introduced by Fudenberg and Tirole (1984) in the context of strategic investment and entry deterrence/accommodation.

demand comes from consumers loyal to its rival’s product, and now it takes a greater price discount to lure these consumers. Such intuition is borne out by results from the model. The three columns of panels in Figure 5 report for the parameterizations with $(\delta, \theta, k^0) = (0.06, 2.2, 0)$ and $v_0 = -\infty, -2,$ and $0,$ respectively.¹¹ The top row of panels plot the change in firm 1’s equilibrium price due to the marginal increase in k^c . They show that the price change is generally positive for the larger firm and negative for the smaller firm. These panels illustrate the asymmetric impact of a marginal increase in k^c on firms’ prices and indicate that the larger firm tends to act as a nonaggressive fat cat by increasing its price. Such asymmetry in firms’ price responses makes it likely that the larger firm will lose consumers to the smaller firm, and therefore there is an increased tendency for the industry to move towards symmetric states. Furthermore, computation results show that this pattern of asymmetric price responses is robust to different parameterizations and different types of equilibria.

The bottom row in Figure 5 plot the relative change in firm 1’s expected sale. They show that as a result of the change in the equilibrium prices, the larger firm’s expected sale drops whereas the smaller firm’s expected sale increases.

Figure 5 also illustrates how the quality of the outside option affects the magnitude of the two firms’ price responses. Specifically, the outside option serves as a non-strategic player and restrains firms’ ability to harvest their locked-in consumers, because these consumers can resort to the outside option if prices charged by the firms are too high. Such a “threat” generated by the outside option can significantly diminish the fat cat effect, as illustrated by the three columns of panels in Figure 5, in which the value for v_0 is successively increased. For example, consider the change in firm 1’s price in state $(20, 0)$. In Panel 1 ($v_0 = -\infty$), the price change is 6.5×10^{-3} , which decreases to 4.3×10^{-3} in Panel 2 ($v_0 = -2$) and 1.4×10^{-3} in Panel 3 ($v_0 = 0$). Similarly, Panels 4-6 show that as v_0 is increased, the relative increase in the smaller firm’s expected sale and the relative decrease in the larger firm’s expected sale are both diminished. Together these panels show that the more attractive is the outside option, the weaker is the fat cat effect.

¹¹For the purpose of comparison, the scale and location of the z -axis are the same for all panels in the same row in Figure 5. This also applies to Figure 6 below.

Top Dog Effect. Whereas an increase in k^c makes the larger firm price less aggressively, an increase in k^f causes the larger firm to act as a top dog by pricing more aggressively. Since k^f affects the firms' equilibrium prices through its impact on the firms' future value function, we first examine how the future value function V' are affected. To highlight the dependence of V' on k^f , we rewrite it as $V'(k^f)$. We then consider the discrete analogue of dV'/dk^f by marginally increasing k^f from k^0 to $k^0 + 0.01$. The top row of panels in Figure 6 plot the resulting changes in firm 1's future value function, denoted by $\Delta V'_1$. In Panel 1, there does not exist an outside option ($v_0 = -\infty$). We see that the increase in k^f enlarges the reward to being a dominant firm: $\Delta V'_1$ is negative for the smaller firm, and increases rapidly for the larger firm as it widens its network size advantage over its rival.

In Panels 1-3, we successively increase the value for v_0 , from $-\infty$ to -2 to 0 . When the quality of the outside option is increased, the dominant firm's ability to charge high prices to exploit its loyal consumers is impaired by the increased competition from the outside option. As a result, the extra reward to being a dominant firm created by the increase in k^f shrinks, as reflected by the flatter climb in $\Delta V'_1$ for the larger firm.

The middle row in Figure 6 plot the change in firm 1's equilibrium price that results from the $\Delta V'_1$ discussed above. We again first consider the case without an outside option, depicted in Panel 4. Here we see that firms drop their prices significantly when they are of comparable size, indicating that the fight for dominance is made much fiercer by the increase in k^f and the resulting extra reward to being a dominant firm. As a network size differential emerges and widens, Δp_1 rises for both the smaller firm and the larger firm, but the smaller firm's price change rises more rapidly than the larger firm's. In fact, the larger firm's price change is always more negative than the smaller firm's, indicating that the increase in k^f causes the larger firm to act as a top dog, by pricing more aggressively than the smaller firm, in order to build and keep its network size advantage. Such pricing behavior increases the tendency towards market dominance.

As we successively increase the quality of the outside option in Panels 4-6, the patterns regarding the firms' price changes persist, but the magnitudes of these price changes are reduced. Firms do not intensify their competition so much when they are of comparable size, as reflected by the modest drop in prices along the diagonal in Panels 5-6. It remains true

that the larger firm's price change is always more negative than the smaller firm's, but the difference between the two firms' price changes shrinks noticeably as v_0 increases, indicating that the top dog effect is diminished by the increased competition from the outside option.

Finally, the bottom row in Figure 6 plot the relative change in firm 1's expected sale that results from the above changes in the firms' equilibrium prices. These panels show that as a result of the top dog effect, the smaller firm's expected sale decreases whereas the larger firm's increases, implying an increased tendency towards market dominance. Furthermore, consistent with our discussion above, the relative changes in the firms' expected sales are diminished as the outside option's quality is increased.

Result 4 (Indirect Channel). *Switching costs also affect firms' expected sales indirectly through their impact on firms' pricing. An increase in the current-period switching cost causes the larger firm to act as a nonaggressive fat cat, which reduces the asymmetry between firms. An increase in the future switching cost causes the larger firm to act as an aggressive top dog, which increases the asymmetry. The existence of a viable outside option diminishes both the fat cat effect and the top dog effect.*

5 Switching Costs and Market Concentration

For the primary dynamic forces of our model to be at work, the relevant part of the parameter space is when the rate of depreciation is neither too low (so that there is customer turnover) nor too high (so that the investment incentive is not weak). In that part of the parameter space, the switching cost and its interaction with the network effect have significant impact on market concentration.

5.1 Fixed Market Size

First consider the case with fixed market size ($v_0 = -\infty$). Here, two forces compete against each other: the fat cat effect, which works against dominance, and the combination of the network solidification effect and the top dog effect, which facilitates dominance. Which of these two forces dominates? Results from this model suggest that the network solidification effect and the top dog effect dominate at low switching cost whereas the fat cat effect takes

over at high switching cost. For example, the top row of panels in Figure 7 plot the expected HHI for $v_0 = -\infty$ and $\delta = 0.05, 0.06, \text{ and } 0.07$, respectively.¹² Each panel reports the HHI for the parameterizations with $\theta \in \{0, 0.2, \dots, 4\}$ and $k \in \{0, 0.2, \dots, 3\}$.

When the network effect is weak, the HHI is low throughout and declines slightly as the switching cost is increased. The equilibrium morphs from Rising equilibrium at low switching cost to Peaked equilibrium at high switching cost.

In contrast, when the network effect is strong ($\theta \geq 2$ in Panel 1, $\theta \geq 2.4$ in Panel 2, and $\theta \geq 2.8$ in Panel 3), the HHI starts with a relatively high level at $k = 0$. As the switching cost increases, the HHI initially increases but later drops significantly. For example, with $\theta = 3$ and $\delta = 0.06$ (Panel 2), the HHI starts with 0.645 at $k = 0$, increases to 0.664 at $k = 1$, then decreases to 0.647 at $k = 1.6$ before plummeting to 0.544 at $k = 1.8$. It then continues to decrease slightly, reaching 0.520 at $k = 3$. A Tipping equilibrium occurs for $k \leq 1.6$ and a Peaked equilibrium occurs for $k \geq 1.8$.

Finally, for some intermediate values of the network effect, the gradual increase in the switching cost causes the equilibrium to change from Rising to Tipping then to Peaked. For example, with $\theta = 2.2$ and $\delta = 0.06$ (in Panel 2), there is a Rising equilibrium at $k = 0$ (HHI = 0.561), a Tipping equilibrium at $k = 1$ (HHI = 0.627; depicted in Figure 1), and a Peaked equilibrium at $k = 2$ (HHI = 0.527; depicted in Figure 2).

5.2 Endogenous Market Size

Turning to the case with a viable outside option (endogenous market size), both the fat cat effect and the top dog effect are diminished by competition from the outside option. On the other hand, the network solidification effect, which increases the asymmetry, continues to operate. Consistent with these observations, results from the model show that in this case, an increase in switching costs increases market concentration. For example, the bottom row of panels in Figure 7 plot the expected HHI for $v_0 = 0$ and $\delta = 0.05, 0.06, \text{ and } 0.07$, respectively. In contrast to the top row, in the bottom row the HHI always increases in the switching cost, indicating that the quality of the outside option plays an important role

¹²In Figure 7, in order to show the details in each panel, the scale of the z -axis is not fixed across different panels.

in determining the effects of switching costs on market concentration. With $v_0 = 0$, there is a Rising equilibrium when the network effect is weak and a Tipping or Mild Tipping equilibrium when the network effect is strong. Examination of the policy functions and the limiting distributions shows that an increase in the switching cost does not change the type of the equilibrium that occurs; instead, it results in the limiting distribution putting more mass in asymmetric states and states close to the origin.

Result 5 (Switching Costs and Market Concentration). *Without a viable outside option, if the network effect is weak then market concentration declines mildly in switching costs, but if the network effect is strong then market concentration first increases and then decreases in switching costs. With a viable outside option, market concentration increases in switching costs.*

This result is depicted in the top two panels in Figure 8.

6 Switching Costs and Prices

In this section we consider the effects of switching costs on prices in network industries. Figure 9 plots the average price (weighted by expected sales and probabilities in the limiting distribution) against the switching cost, with $\delta = 0.06$. $v_0 = -\infty$ in the left column of panels and $v_0 = 0$ in the right column. From the top row to the bottom row, θ is 0, 1, 2, 3, 4, respectively. The figure reveals the following patterns. First, without an outside option ($v_0 = -\infty$), the average price generally increases in the switching cost (the left column). Second, with an outside option ($v_0 = 0$), the average price tends to decrease in the switching cost when the network effect is modest (Panels 2, 4, and 6) and increase in the switching cost when the network effect is strong (Panel 10). Third, the changes in the average price caused by the changes in the switching cost are much bigger when $v_0 = -\infty$ than when $v_0 = 0$. Results from a broad set of parameterizations confirm these findings and are reported in the Appendix.

6.1 The Four Effects of Switching Costs

To understand the above patterns, we start by examining how the average price is affected by the four effects of switching costs. In the direct channel, the network solidification effect and the market contraction effect represent a movement on the price surface, since the firms' price policy functions are fixed but the position of the industry state is changed. On the other hand, in the indirect channel, the fat cat effect and the top dog effect represent both a shift in the price surface and a movement on the price surface: the firms change their price policy functions in response to a change in the switching cost, and furthermore the position of the industry state is also changed.

First consider the network solidification effect. Examination of the policy functions in all the parameterizations with $\theta > 0$ shows that an asymmetry movement of the state causes the average price to increase except when there is a Peaked equilibrium (for an example of the latter see Panel 1 in Figure 2). An asymmetry movement represents a widening of the installed base differential between the two firms, allowing the larger firm to charge a higher price and drive up the average price—except when there is a Peaked equilibrium, in which case both firms drop their prices when the state moves away from the symmetric peak. Therefore, the network solidification effect, which generally causes asymmetry movements of the state, increases the average price except when there is a Peaked equilibrium.

Next consider the market contraction effect. Examination of the policy functions in all the parameterizations with $v_0 \in \{-2, 0\}$ shows that a contraction movement of the state causes the average price to decrease. A contraction movement represents a reduction in the size of the market, and firms find it optimal to lower their prices in response. Therefore, the market contraction effect, which shrinks the market size by making the inside goods less attractive relative to the outside option, reduces the average price.

Next consider the fat cat effect. The main feature of this effect is a price increase by the larger firm in order to harvest its loyal consumers, which tends to increase the average price. On the other hand, the fat cat effect also drives the industry towards symmetric states, which tends to decrease the average price (except when there is a peaked equilibrium, as discussed above). To assess the overall effect on the average price, I conduct the type of counterfactuals reported in Figure 5 for a broad set of parameterizations ($v_0 \in \{-\infty, -2, 0\}$,

$\delta \in \{0.04, 0.05, \dots, 0.1\}$, $\theta \in \{0, 0.2, \dots, 4\}$, and $k^0 \in \{0, 0.2, \dots, 3\}$), and compute the change in the average price in each counterfactual. The results indicate that the net impact of the fat cat effect on the average price is predominantly positive.

Finally, consider the top dog effect. The main feature of this effect is a price reduction by the larger firm in order to build and keep its network size advantage, which tends to decrease the average price. On the other hand, the top dog effect also pulls the industry towards asymmetric states, which tends to increase the average price. To assess the overall effect on the average price, I conduct the type of counterfactuals reported in Figure 6 for the same set of parameterizations as above, and compute the change in the average price in each counterfactual. The results indicate that the net impact of the top dog effect on the average price is also predominantly positive.

6.2 The Outside Option and the Strength of the Network Effect

The above analysis sheds light on the patterns we observe regarding the effects of switching costs on the average price. Among the four effects, the main force that reduces the average price is the market contraction effect. Without an outside option, the market contraction effect does not operate, and therefore the average price increases in the switching cost. As the quality of the outside option v_0 increases, the market contraction effect is strengthened, making it more likely that an increase in the switching cost will cause the average price to drop.

The relationship between switching costs and price also critically depends on the strength of network effect, particularly when there exists a viable outside option. As v_0 increases, the Peaked equilibrium gradually becomes extinct, and therefore any asymmetry movement of the industry state tends to raise the average price. Under this circumstance, a stronger network effect amplifies the network solidification effect to make it more likely that the average price will increase in the switching cost. The amplification happens in two ways.

First, the basic function of the network solidification effect is that it gives the larger firm an extra advantage by making the installed base differential longer-lasting. At the same time, the fundamental property of network effects is that they create a “bandwagon” or “snowball” effect that allows a small base differential to quickly widen. Hence, a stronger

network effect expands the extra advantage for the larger firm that is created by the network solidification effect and causes the larger firm to price even more aggressively as a “top dog” (recall that the top dog effect is based on the network solidification effect in future periods), thus giving rise to a larger increase in the asymmetry in the industry.

Second, a stronger network effect translates an installed base differential into a larger quality differential and allows the larger firm to raise its price more substantially. To illustrate, Figure 10 plots the policy functions for two parameterizations that differ only in θ : $\theta = 1$ in Panel 1 and $\theta = 3$ in Panel 2. The biggest difference between the two policy functions is that as a firm gains an installed base advantage over its rival, its price increases only mildly in Panel 1 but significantly in Panel 2. For instance, when the state moves parallel to the $(0, 20) - (20, 0)$ diagonal from $(8, 8)$ to $(14, 2)$, in Panel 1 firm 1’s price increases only 7.1% from 1.19 to 1.27, whereas in Panel 2 its price increases a sizeable 59.4% from 0.86 to 1.37. Therefore, when the network solidification effect and the top dog effect of switching costs cause the industry to move towards asymmetric states, a stronger network effect translates such asymmetry movements into larger price increases by the larger firm, making it more likely that the overall impact of the switching cost on the average price is positive.

Thus the key to understanding the effects of switching costs on the average price lies in understanding the ability of the outside option to induce the market contraction effect, as well as the ability of the network effect to amplify the network solidification effect and the top dog effect. Results from the current model then offer a new perspective on the price puzzle of switching costs discussed in the Introduction, by showing that both scenarios (“prices increase in switching costs” and “prices decrease in switching costs”) can arise as equilibrium outcomes and that network effects and competition from the outside option are key determinants.

Result 6 (Switching Costs and Prices). *Without a viable outside option, the average price increases in switching costs. With a viable outside option, if the network effect is modest then the average price decreases in switching costs, but if the network effect is strong then the average price increases in switching costs.*

This result is depicted in the bottom two panels in Figure 8.

Additionally, the Appendix reports on the effects of switching costs on producer surplus, consumer surplus, and total welfare. The results there show that consumers are harmed by switching costs. Even when firms benefit from switching costs, consumers' losses more than offset firms' gains and result in a reduction in total welfare. In the case with a viable outside option, both firms and consumers will benefit from a reduction in switching costs. If the outside option is fairly inferior, a reduction in switching costs will benefit consumers but hurt firms.

7 Conclusion

Consumer switching costs are inherent in most network industries, yet the role of switching costs in such industries remains largely unexplored. To investigate the effects of switching costs on industry dynamics and market outcome in network industries, I develop a dynamic model of price competition with both network effects and switching costs. While the existing literature on network industries assume that the consumers who make purchasing decisions are always new, in the sense that they do not face any switching costs, in my model these consumers can be new or loyal to one of the firms. This new modeling captures the idea that the networks compete for not only new consumers but also partially locked-in consumers, and allows me to directly assess the role of switching costs in network industries.

I provide a series of results that characterize the effects of switching costs on market concentration and prices. These results show that the role of switching costs critically depends on the strength of the network effect and the quality of the outside option. A good understanding of these patterns will allow regulators to make informed decisions regarding public policies that alter switching costs, such as phone number portability in the mobile phone industry, account number portability in the banking industry, and the adoption of open standards in the software industry.

Finally, in this paper I have had to make some simplifying assumptions to facilitate the computation. On the demand side, consumers are myopic and choose the good that offers the highest current utility. On the supply side, qualities of the products are exogenous and firms compete in prices but not in qualities. Relaxing these assumptions in future research

will prove useful. Nevertheless, one unambiguous lesson we learn from the current analysis is that effective policy-making in network industries must pay attention to switching costs and their interactions with network effects and the outside option, which are shown to have critical influence on industry dynamics and market outcome.

References

- Arie, G. and P. L. E. Grieco (2010). Who Pays for Switching Costs? Northwestern University.
- Barla, P. (2000). Firm size inequality and market power. *International Journal of Industrial Organization* 18, 693–722.
- Beggs, A. and P. Klemperer (1992). Multi-Period Competition with Switching Costs. *Econometrica* 60(3), 651–666.
- Besanko, D., U. Doraszelski, Y. Kryukov, and M. Satterthwaite (2010). Learning-by-Doing, Organizational Forgetting, and Industry Dynamics. *Econometrica* 78(2), 453–508.
- Cabral, L. (2008). Switching Costs and Equilibrium Prices. New York University.
- Cabral, L. (2009). Dynamic Price Competition with Network Effects. *Review of Economic Studies*. Forthcoming.
- Casson, T. and P. S. Ryan (2006). Open Standards, Open Source Adoption in the Public Sector, and Their Relationship to Microsoft’s Market Dominance. In S. Bolin (Ed.), *Standards Edge: Unifier or Divider?*, pp. 87–99. Sheridan Books.
- Chen, J., U. Doraszelski, and J. Harrington (2009). Avoiding Market Dominance: Product Compatibility in Markets with Network Effects. *RAND Journal of Economics* 40(3), 455–485.
- Chen, Y. and R. Rosenthal (1996). Dynamic duopoly with slowly changing customer loyalties. *International Journal of Industrial Organization* 14, 269–296.

- Chiang, A. and K. Wainwright (2005). *Fundamental Methods of Mathematical Economics* (4th ed.). McGraw-Hill/Irwin.
- Clements, M. and H. Ohashi (2005). Indirect Network Effects and the Product Cycle: U.S. Video Games, 1994 - 2002. *Journal of Industrial Economics* 53, 515–542.
- Compte, O., F. Jenny, and P. Rey (2002). Capacity constraints, mergers and collusion. *European Economic Review* 46, 1–29.
- Doganoglu, T. (2005). Switching Costs, Experience Goods and Dynamic Price Competition. University of Munich.
- Doganoglu, T. and L. Grzybowski (2005). Dynamic Duopoly Competition with Switching Costs and Network Externalities. University of Munich.
- Doraszelski, U. and S. Markovich (2007). Advertising Dynamics and Competitive Advantage. *RAND Journal of Economics* 38, 557–592.
- Doraszelski, U. and M. Satterthwaite (2010). Computable Markov-Perfect Industry Dynamics. *Rand Journal of Economics* 41(2), 215–243.
- Dranove, D. and N. Gandal (2003). The DVD vs. DIVX standard war: Network effects and empirical evidence of preannouncement effects. *Journal of Economics and Management Strategy* 12, 363–386.
- Dubé, J.-P., G. J. Hitsch, and P. E. Rossi (2009). Do Switching Costs Make Markets Less Competitive? *Journal of Marketing Research* 46, 435–445.
- Dubé, J.-P. H., G. J. Hitsch, and P. K. Chintagunta (2010). Tipping and Concentration in Markets with Indirect Network Effects. *Marketing Science* 29(2), 216–249.
- ECAFSS (2006). Competition Issues In Retail Banking and Payments Systems Markets In The EU. European Competition Authorities Financial Services Subgroup.
- ECC (2005). Implementation of Mobile Number Portability In CEPT Countries. Electronic Communications Committee (ECC) within the European Conference of Postal and Telecommunications Administrations (CEPT).

- Economides, N. (1996). The Economics of Networks. *International Journal of Industrial Organization* 14, 673–699.
- Farrell, J. and P. Klemperer (2007). Coordination and Lock-in: Competition with Switching Costs and Network Effects. In M. Armstrong and R. Porter (Eds.), *Handbook of Industrial Organization*, Volume 3. Elsevier.
- Fudenberg, D. and J. Tirole (1984). The fat-cat effect, the puppy-dog ploy and the lean and hungry look. *American Economic Review* 74, 361–366.
- Gandal, N., M. Kende, and R. Rob (2000). The Dynamics of Technological Adoption in Hardware/Software Systems: The Case of Compact Disc Players. *Rand Journal of Economics* 31, 43–61.
- Klemperer, P. (1987). Markets with Consumer Switching Costs. *Quarterly Journal of Economics* 102, 375–394.
- Klemperer, P. (1995). Competition when Consumers have Switching Costs: An Overview with Applications to Industrial Organization, Macroeconomics, and International Trade. *The Review of Economic Studies* 62, 515–539.
- Laffont, J.-J., P. Rey, and J. Tirole (1998). Network Competition: II. Price Discrimination. *RAND Journal of Economics* 29(1), 38–56.
- Llobet, G. and M. Manove (2006). Network Size and Network Capture. Boston University.
- Mitchell, M. F. and A. Skrzypacz (2006). Network externalities and long-run market shares. *Economic Theory* 29, 621–648.
- Pakes, A. and P. McGuire (1994). Computing Markov-Perfect Nash Equilibria: Numerical Implications of a Dynamic Differentiated Product Model. *The RAND Journal of Economics* 25(4), 555–589.
- Pakes, A. and P. McGuire (2001). Stochastic Algorithms, Symmetric Markov Perfect Equilibrium, and the ‘Curse’ of Dimensionality. *Econometrica* 69(5), 1261–1281.

- Park, M. (2009). The Economic Impact of Wireless Number Portability. University of Minnesota.
- Shy, O. (2001). *The Economics of Network Industries*. Cambridge University Press.
- Suleymanova, I. and C. Wey (2008). Bertrand Competition in Markets with Network Effects and Switching Costs. DIW Berlin.
- Taylor, C. (2003). Supplier surfing: Competition and consumer behavior in subscription markets. *RAND Journal of Economics* 34, 223–246.
- To, T. (1996). Multi-Period Competition with Switching Costs: An Overlapping Generations Formulation. *The Journal of Industrial Economics* 44(1), 81–87.
- Train, K. E. (2003). *Discrete Choice Methods with Simulation*. Cambridge University Press.
- Vasconcelos, H. (2005). Tacit Collusion, Cost Asymmetries, and Mergers. *RAND Journal of Economics* 36, 39–62.
- Viard, V. B. (2007). Do switching costs make markets more or less competitive? The case of 800-number portability. *Rand Journal of Economics* 38, 146–163.

(1) Firm 1's policy function

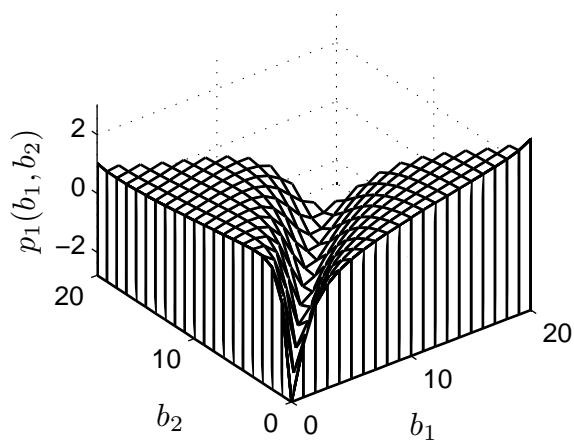

(2) Firm 1's value function

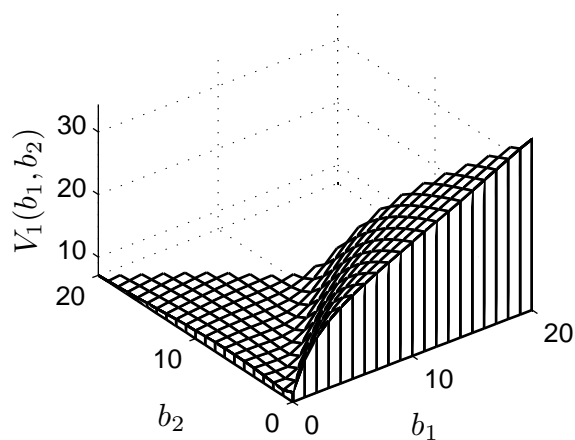

(3) Transient distribution after 15 periods

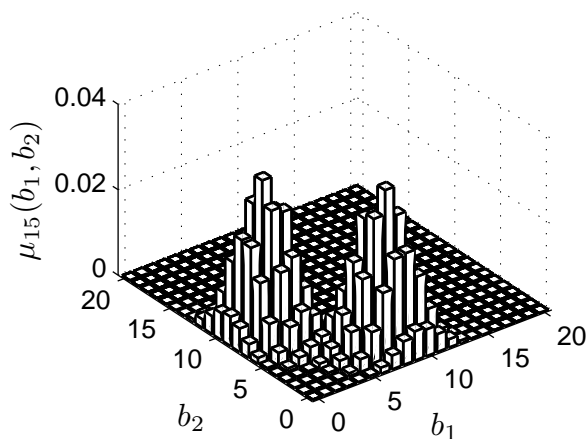

(4) Limiting distribution

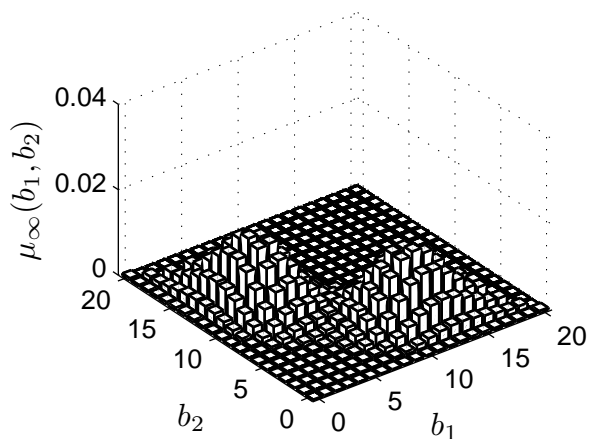

(5) Probability that firm 1 makes a sale

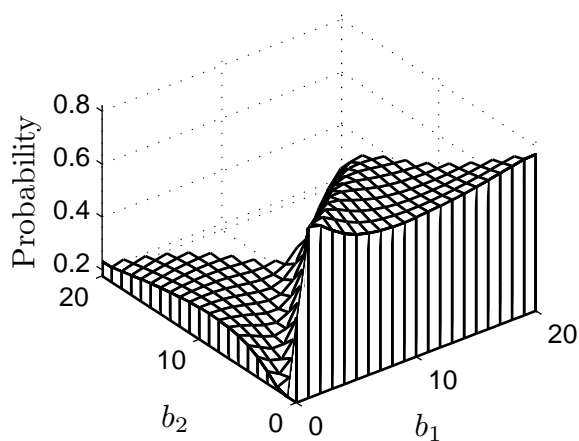

(6) Resultant forces

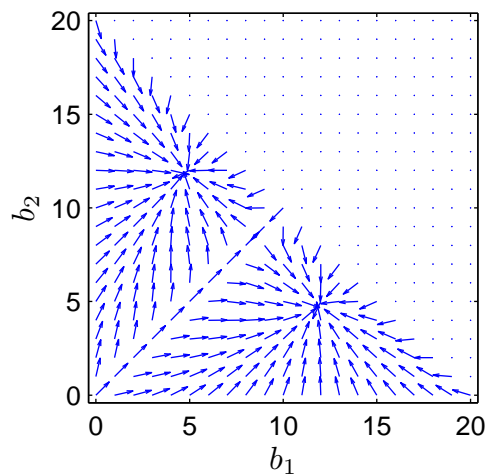
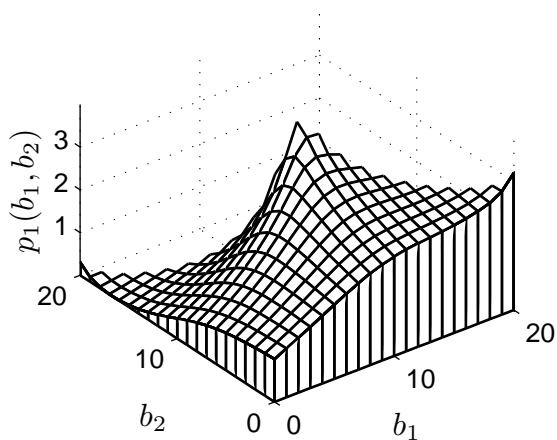
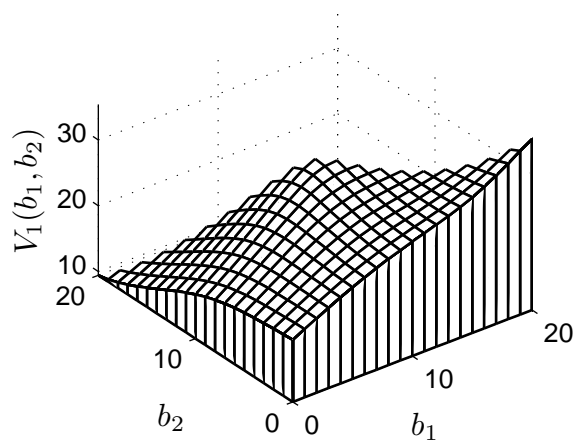

Figure 1. Tipping equilibrium: $v_0 = -\infty$, $\delta = 0.06$, $\theta = 2.2$, $k = 1$

(1) Firm 1's policy function



(2) Firm 1's value function



(3) Transient distribution after 15 periods

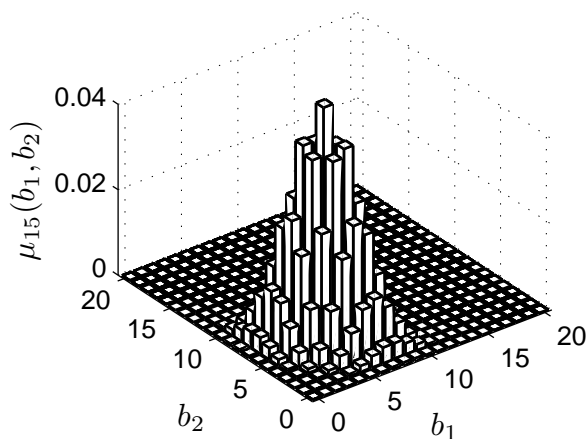

(4) Limiting distribution

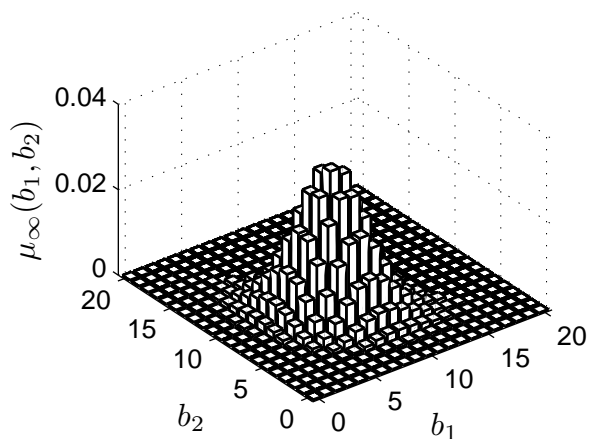

(5) Probability that firm 1 makes a sale

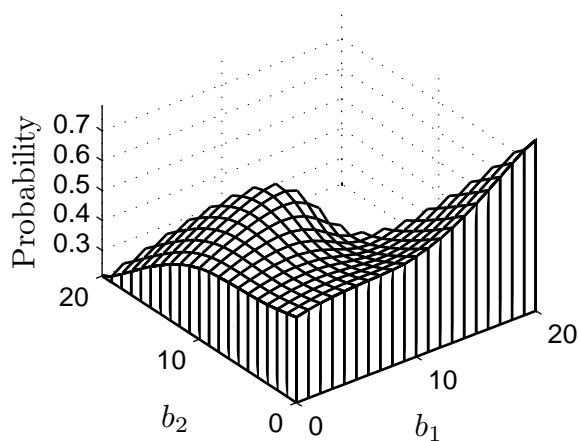

(6) Resultant forces

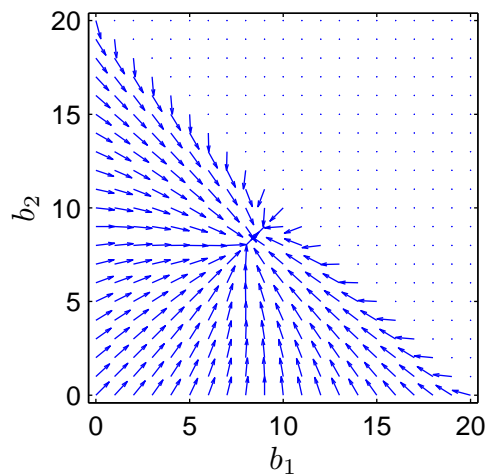

Figure 2. Peaked equilibrium: $v_0 = -\infty$, $\delta = 0.06$, $\theta = 2.2$, $k = 2$

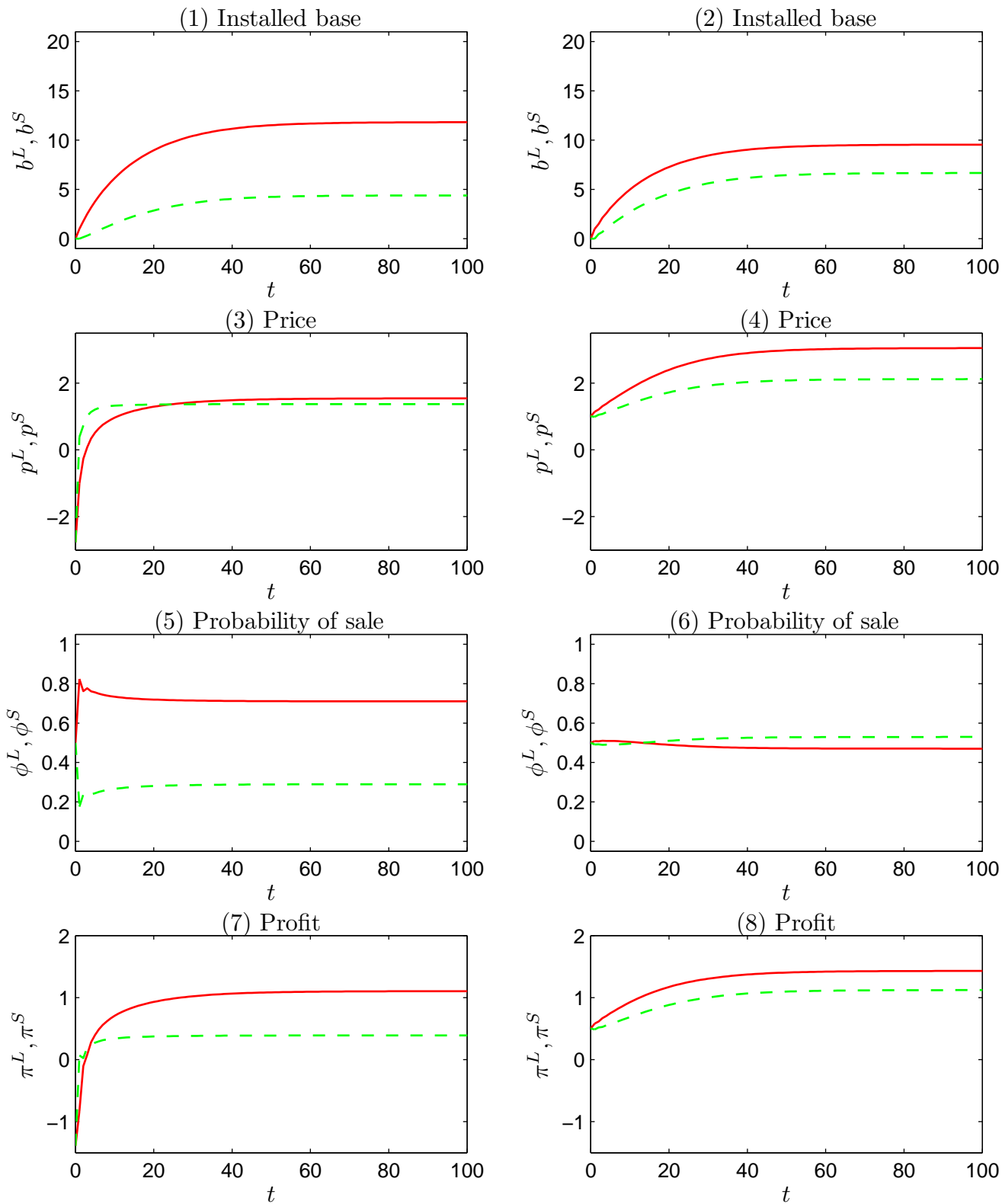

Figure 3. Time paths. Left column: Tipping equilibrium. Right column: Peaked equilibrium. Solid line: the larger firm. Dashed line: the smaller firm.

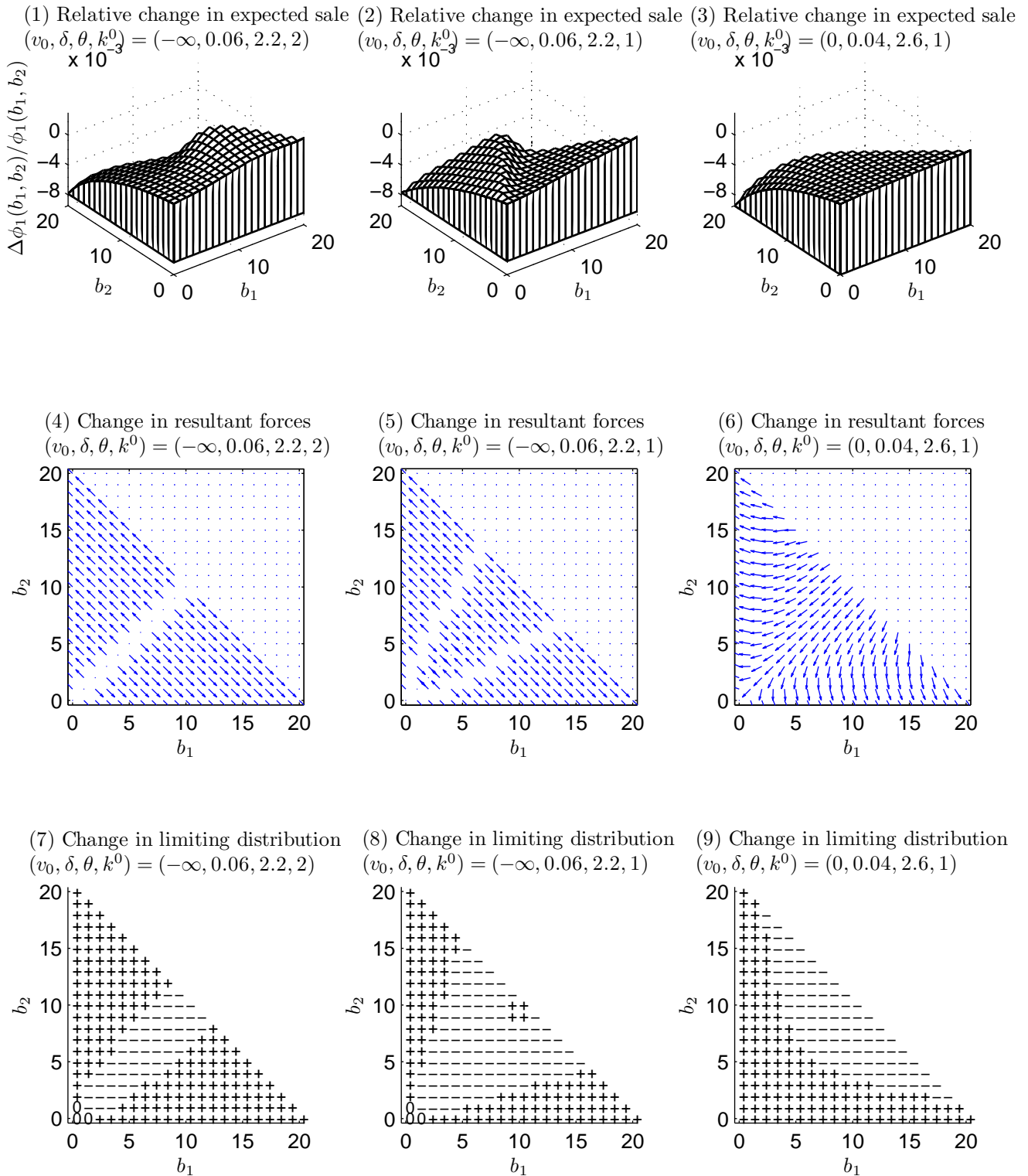

Figure 4. Network solidification effect and market contraction effect.

Left column: Peaked equilibrium. Center column: Tipping equilibrium. Right column: Mild Tipping equilibrium. k^c is marginally increased from k^0 to $k^0 + 0.01$.

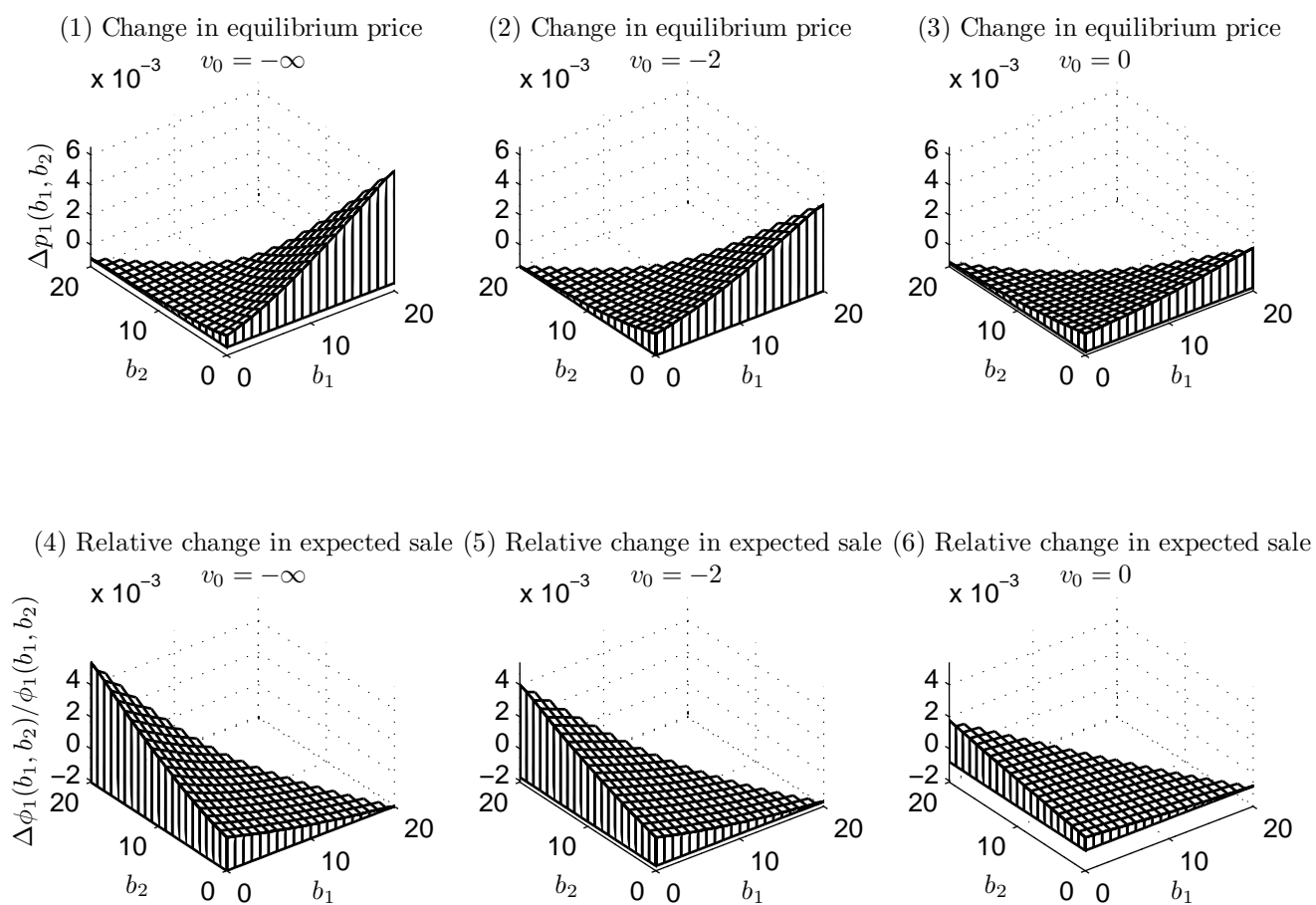

Figure 5. Fat cat effect of switching costs: $\delta = 0.06$, $\theta = 2.2$, $k^0 = 0$.

Top row: change in equilibrium price when current-period switching cost k^c is marginally increased from k^0 to $k^0 + 0.01$ while future switching cost k^f is fixed at k^0 .

Bottom row: relative change in expected sale due to change in equilibrium price.

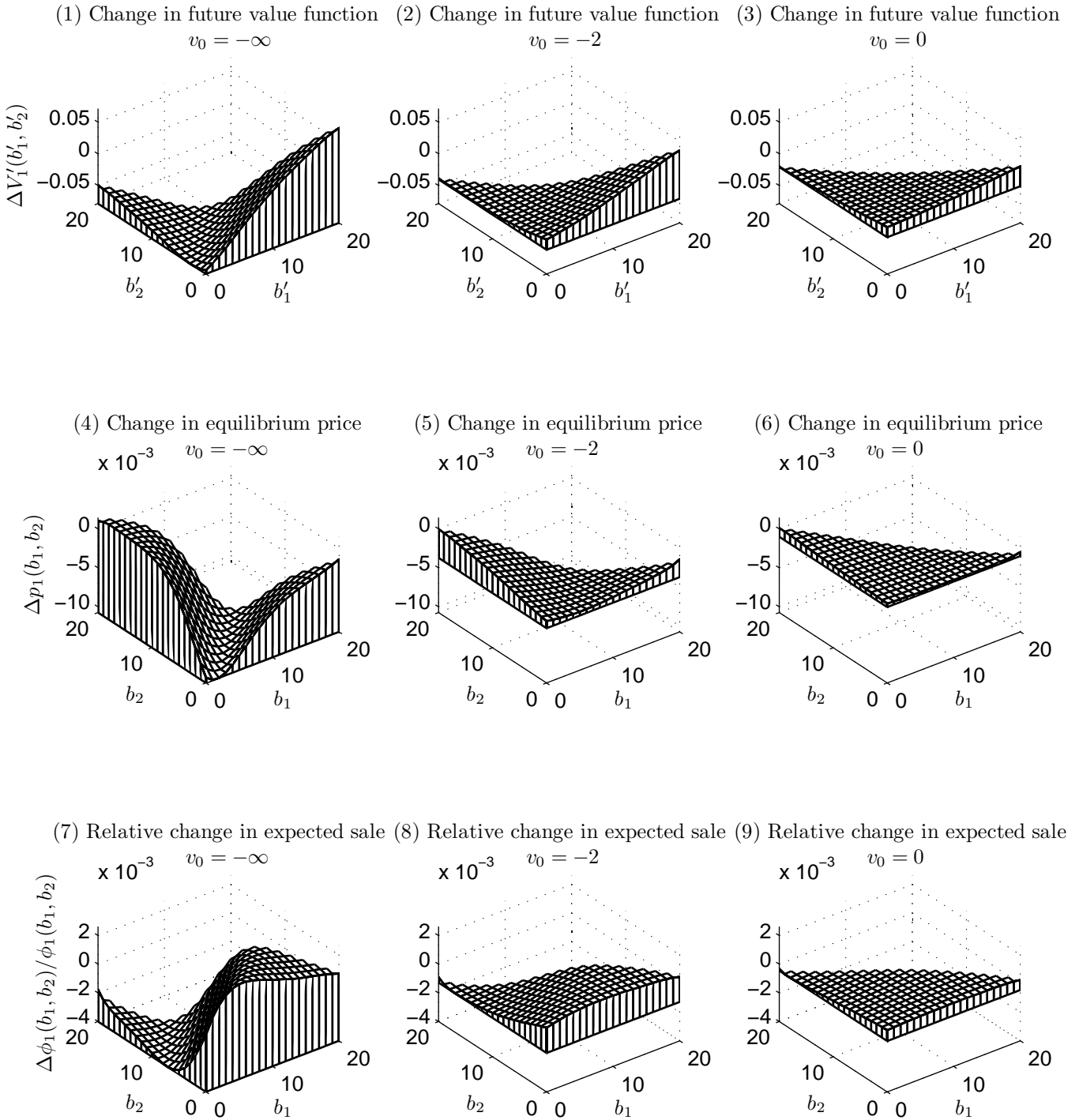
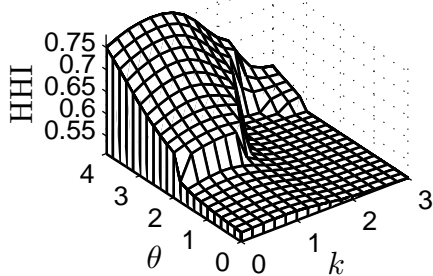

Figure 6. Top dog effect of switching costs: $\delta = 0.06$, $\theta = 2.2$, $k^0 = 0$.

Presents changes in future value function, equilibrium price, and expected sale, when future switching cost k^f is marginally increased from k^0 to $k^0 + 0.01$ while current-period switching cost k^c is fixed at k^0 .

(1) $v_0 = -\infty, \delta = 0.05$



(2) $v_0 = -\infty, \delta = 0.06$

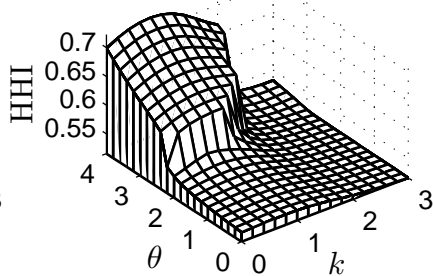

(3) $v_0 = -\infty, \delta = 0.07$

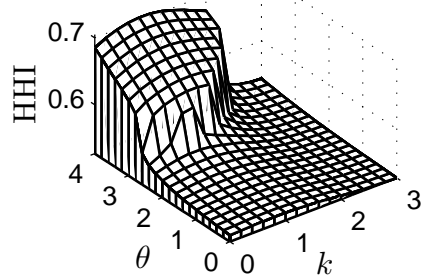

(4) $v_0 = 0, \delta = 0.05$

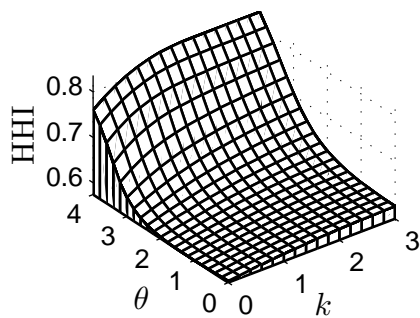

(5) $v_0 = 0, \delta = 0.06$

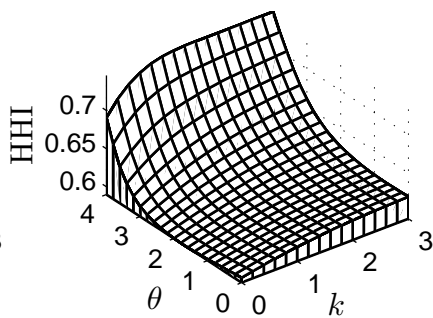

(6) $v_0 = 0, \delta = 0.07$

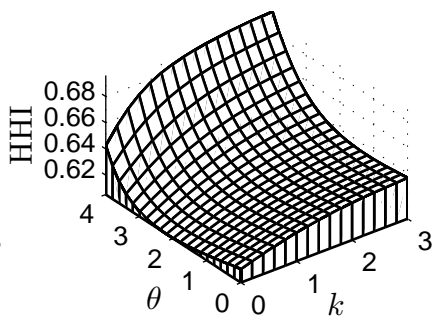
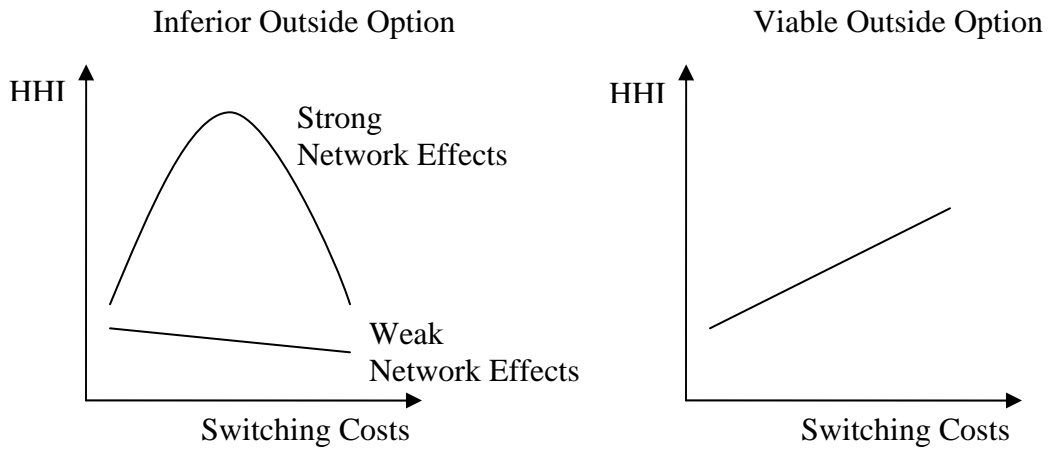

Figure 7. Expected HHI

Figure 8. The effects of switching costs in network industries: A summary

(1) Effects on market concentration



(2) Effects on prices

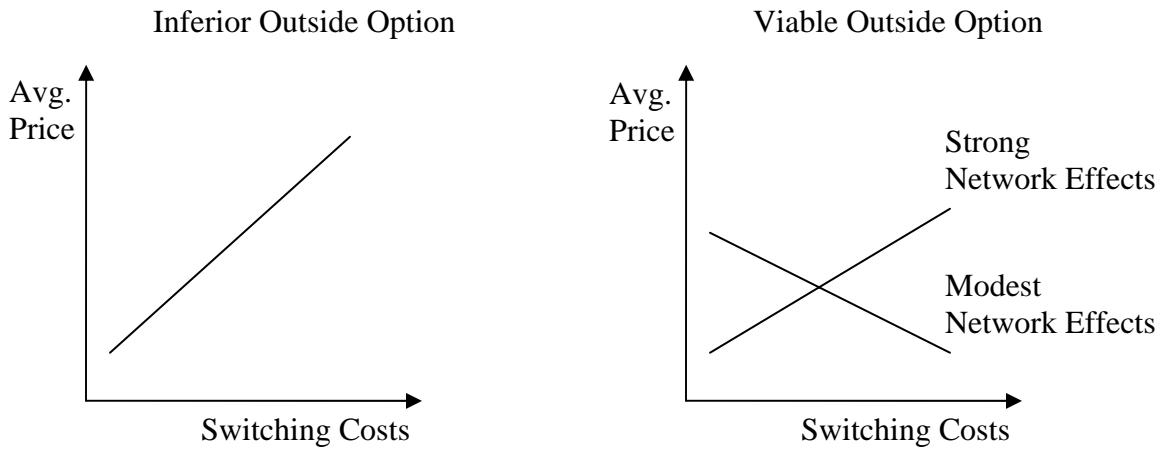

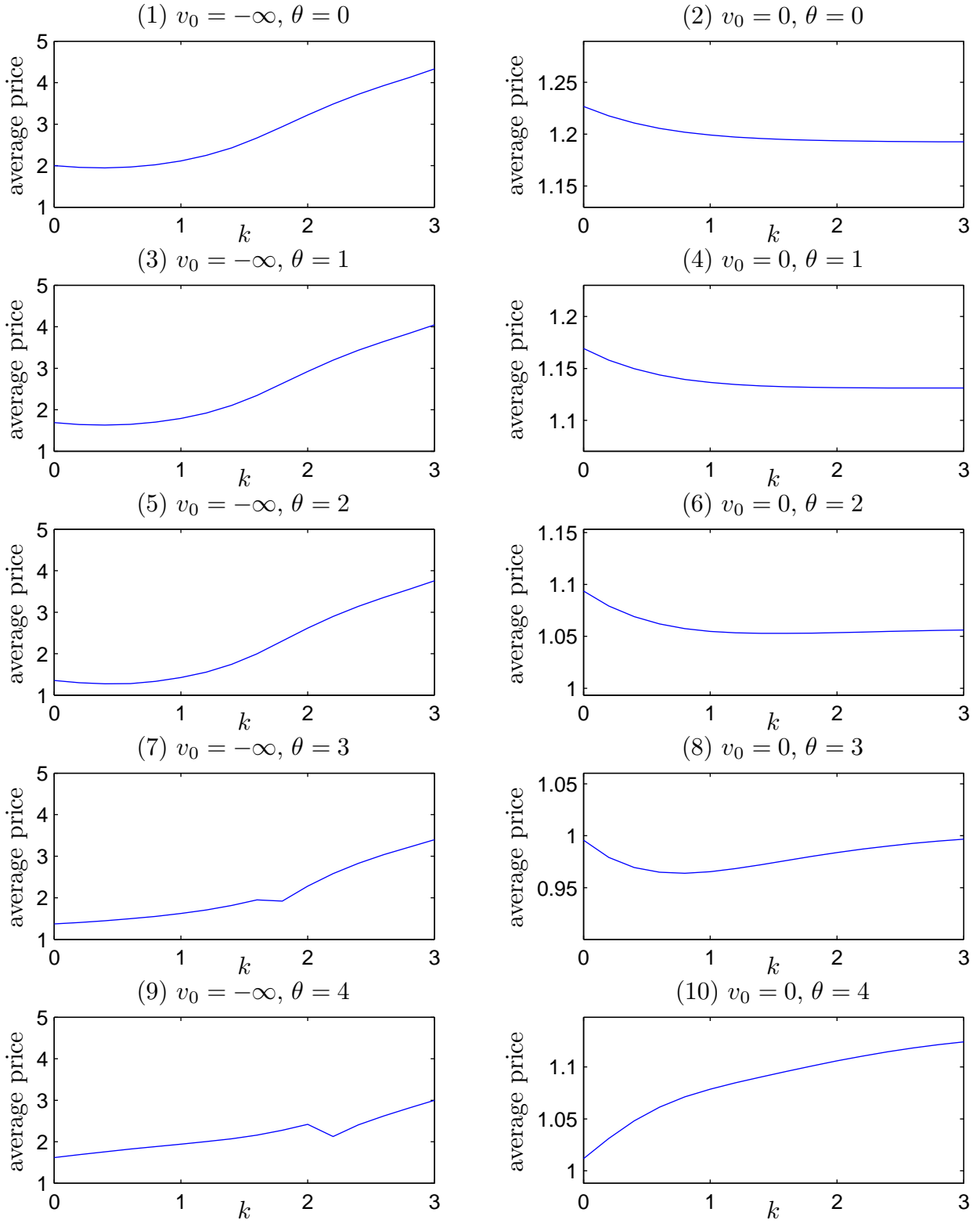

Figure 9. Average price: $\delta = 0.06$

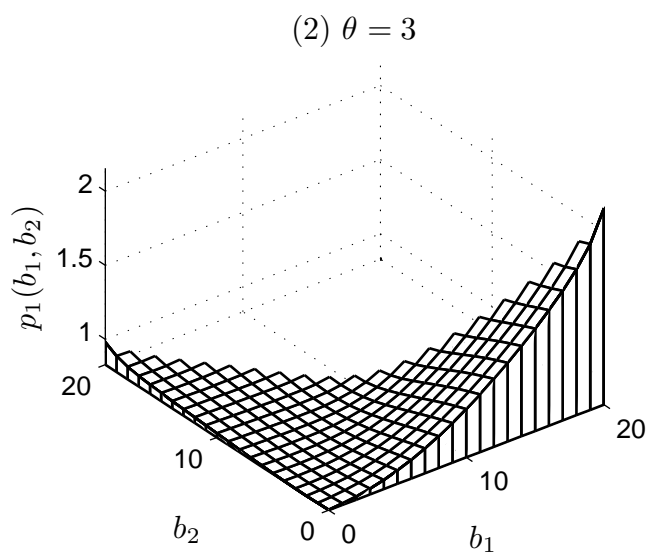
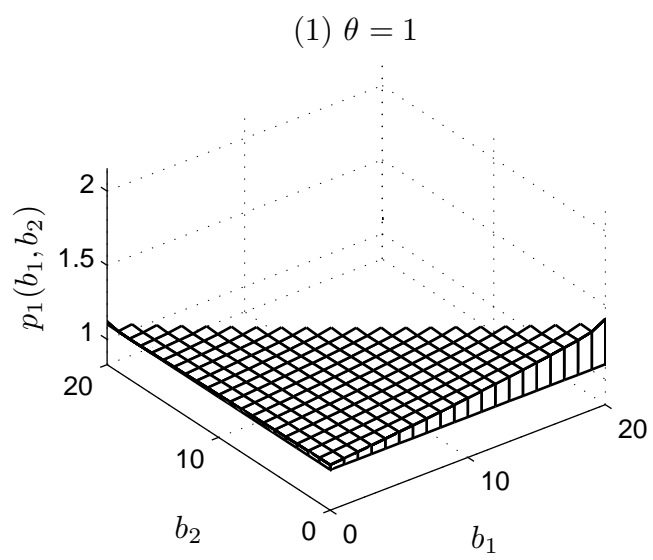

Figure 10. Firm 1's policy function: $v_0 = 0$, $\delta = 0.05$, $k = 0$

Appendix

1 Deriving the First-order Condition

Let $\psi_i(b, p)$ denote the objective function in the maximization problem in Firm i 's Bellman equation, Eq. (4):

$$\psi_i(b, p) \equiv E_r \left[\phi_{ri}(b, p_i, p_{-i}(b))p_i + \beta \sum_{j=0}^N \phi_{rj}(b, p_i, p_{-i}(b))\bar{V}_{ij}(b) \right].$$

Below we derive the first-order condition. First,

$$\frac{\partial \psi_i(b, p)}{\partial p_i} = 0 \Leftrightarrow E_r \left[\frac{\partial \phi_{ri}}{\partial p_i} p_i + \phi_{ri} + \beta \sum_{j=0}^N \frac{\partial \phi_{rj}}{\partial p_i} \bar{V}_{ij} \right] = 0.$$

Using the properties of logit demand:¹

$$\begin{aligned} \frac{\partial \phi_{ri}}{\partial p_i} &= \frac{\partial \bar{u}_{ri}}{\partial p_i} \phi_{ri}(1 - \phi_{ri}) = -\phi_{ri}(1 - \phi_{ri}), \text{ and} \\ \frac{\partial \phi_{rj}}{\partial p_i} &= -\frac{\partial \bar{u}_{ri}}{\partial p_i} \phi_{ri} \phi_{rj} = \phi_{ri} \phi_{rj}, \text{ for } j \neq i, \end{aligned}$$

where \bar{u}_{ri} is the utility that a consumer loyal to good r gets from buying good i , excluding ϵ_i :

$$\bar{u}_{ri} = v_i + \mathbf{1}(i \neq 0)\theta g(b_i) - p_i - \mathbf{1}(r \neq 0, i \neq 0, i \neq r)k.$$

Therefore,

$$\begin{aligned} \frac{\partial \psi_i(p_i; b)}{\partial p_i} = 0 &\Leftrightarrow E_r \left[-\phi_{ri}(1 - \phi_{ri})p_i + \phi_{ri} + \beta [-\phi_{ri}(1 - \phi_{ri})]\bar{V}_{ii} + \beta \sum_{j \neq i} \phi_{ri} \phi_{rj} \bar{V}_{ij} \right] = 0 \\ &\Leftrightarrow E_r \left[-\phi_{ri}(1 - \phi_{ri})(p_i + \beta \bar{V}_{ii}) + \phi_{ri} + \beta \phi_{ri} \sum_{j \neq i} \phi_{rj} \bar{V}_{ij} \right] = 0. \end{aligned}$$

2 Mild Tipping Equilibrium

When there exists an outside option, there is a variant to Tipping equilibrium. In this variant, referred to as a *Mild Tipping* equilibrium, the modes of the limiting distribution are asymmetric but a fair amount of mass is spread over the reasonably symmetric states between the two modes, as exemplified by Figure A1.

With a viable outside option, firms' payoff to having an installed base advantage is reduced, as the outside option serves as a non-strategic player and restrains firms' ability to

¹See Train (2003, page 62).

exploit the locked-in consumers. For example, in the Tipping equilibrium shown in Figure 1, the increase in firm 1’s value from state $(0, 0)$ to state $(2, 0)$ is $15.91 - 8.58 = 7.33$, whereas in the Mild Tipping equilibrium shown in Figure A1, the increase is only $5.77 - 4.70 = 1.07$. As a result, when firms are of comparable size, they do not fight so fiercely in a Mild Tipping equilibrium as in a Tipping equilibrium. In Figure 1, the policy function features a deep trench along and around the diagonal, in which firms’ prices are often negative (below cost). On the diagonal, prices range from $p_1(0, 0) = -2.78$ to $p_1(10, 10) = 0.29$. In contrast, in the policy function in Figure A1, although prices are still lowest when firms are of comparable size, there does not exist a visible trench. Moreover, prices are always positive. On the diagonal, prices range from $p_1(0, 0) = 0.74$ to $p_1(10, 10) = 0.92$. As a consequence of the relatively mild competition along the diagonal, the smaller firm finds it less painful to try to catch up: doing so does not involve going through a highly unprofitable trench. In response, the smaller firm does not give up the fight as completely as in a Tipping equilibrium. For example, in Figure 1, the smaller firm’s price in states $(0, 0)$, $(0, 1)$, $(0, 2)$, $(0, 3)$ and $(0, 4)$ are -2.78 , 0.39 , 1.37 , 1.54 , and 1.55 , respectively, showing a substantial increase in price once the firm lags behind. In contrast, in Figure A1, the smaller firm’s price in those states are 0.74 , 0.74 , 0.75 , 0.76 , and 0.77 , respectively, indicating that the smaller firm keeps its price relatively low in hope of reducing the base differential and catching up with the larger firm. Such pricing behavior explains why the industry spends a fair amount of time in the reasonably symmetric states between the two modes.

Turning to expected sales, we see that in a Mild Tipping equilibrium, the larger firm still has a higher probability of making a sale than the smaller firm, but the difference is less significant than in a Tipping equilibrium. Correspondingly, the resultant forces show that the tendency for the industry to move away from the diagonal is weaker than in a Tipping equilibrium.

3 Switching Costs and Prices: Detailed Results

Table A1 reports on the effects of switching costs on the average price from a broad set of parameterizations. They confirm the findings reported in Section 6.

The table reports statistics for the percentage change in the equilibrium average price when the switching cost increases from k to $k+0.2$, for $v_0 \in \{-\infty, -2, 0\}$, $\delta \in \{0.04, 0.05, \dots, 0.1\}$, $\theta \in \{0, 0.2, \dots, 4\}$, and $k \in \{0, 0.2, \dots, 2.8\}$. In the table, the parameterizations are first grouped according to the value of v_0 , and then within each v_0 group, they are further divided into subgroups according to the value of θ . The statistics reported are the 5th, 25th, 50th, 75th, and 95th percentiles, as well as the percentage of negative changes.

The first three rows in the table show that the quality of the outside option plays an important role in determining the effects of switching costs on price. An increase in the switching cost tends to increase price if there does not exist an outside option, but this is gradually reversed as the quality of the outside option increases. When $v_0 = -\infty$, an increase in the switching cost reduces price only 10.1% of the time (that is, for 10.1% of the parameterizations considered). That number increases to 20.7% for $v_0 = -2$, and further jumps to 62% for $v_0 = 0$. Furthermore, as the outside option becomes more attractive, the impact of switching costs on price is diminished. For example, as v_0 increases from $-\infty$ to 0, the 25th-75th percentile interval moves down and narrows from [2.83%, 6.98%] to

$[-0.24\%, 0.09\%]$. The outside option is a non-strategic player whose competition weakens firms' ability to change their prices in response to the switching costs.

The remaining rows in the table show that a stronger network effect makes it more likely that the average price will increase in the switching cost. This pattern is particularly salient when there exists a viable outside option. For example, with $v_0 = -2$, the percentage of negative price changes is 33.3% when $\theta \in [0, 1)$, but drops to 12.4% when $\theta \in [3, 4]$. With $v_0 = 0$, the percentage of negative price changes is 93.7% when $\theta \in [0, 1)$, but drops dramatically to 27.0% when $\theta \in [3, 4]$. In the case with $v_0 = 0$, the increase of θ from $[0, 1)$ to $[3, 4]$ results in the median changing from negative (-0.08%) to positive (0.18%).

4 Switching Costs and Welfare

Here we examine the effects of switching costs on expected producer surplus, consumer surplus, and total welfare (the sum of the previous two measures), based on the limiting distribution.² We consider the changes in the equilibrium levels of these measures when the switching cost increases from k to $k + 0.2$, for $v_0 \in \{-\infty, -2, 0\}$, $\delta \in \{0.04, 0.05, \dots, 0.1\}$, $\theta \in \{0, 0.2, \dots, 4\}$, and $k \in \{0, 0.2, \dots, 2.8\}$.

Table A2 reports statistics for the percentage change in producer surplus. It shows that switching costs help the firms when there does not exist an outside option, but become more and more harmful to the firms as v_0 increases. Producer surplus increases in the switching cost 89.9% of the time when $v_0 = -\infty$, but decreases in the switching cost 92.5% of the time when $v_0 = 0$. For a same v_0 , a stronger network effect makes it more likely that the firms will benefit from the switching cost. For example, with $v_0 = -2$, the firms suffer a loss due to an increase in the switching cost 86.1% of the time if $\theta \in [0, 1)$, but only 14.0% of the time if $\theta \in [3, 4]$.

The existence of an outside option gives consumers greater flexibility in their product choices and restrains firms' ability to raise prices. Therefore a stronger outside option makes switching costs more harmful to firms and less harmful to consumers. On the other hand, when the network effect is strong, switching costs are less capable of reducing the size of the market and more likely to result in price increases, and hence firms are more likely to benefit from switching costs.

Prior studies on switching costs, which often assume a fixed market size and do not consider network effects, tend to find that switching costs raise oligopoly profits (see Farrell and Klemperer (2007, Section 2.4.4.) and the references cited therein). By incorporating network effects and allowing the market size to be endogenously determined, this model allows us to look at a broader picture, in which the relationship between switching costs and firm profits depends on the strength of network effect and the quality of the outside option.

Turning to consumer surplus (Table A3) and total welfare (Table A4), we find that

²The producer surplus is equal to the combined profits of the firms, and the consumer surplus is the log-sum term (Train (2003)). In the case without an outside option, the producer surplus is equal to the average price, since the sum of the firms' expected sales is always 1 and the marginal cost is normalized to 0.

both of them consistently decrease in the switching cost.³ Furthermore, the magnitude of the decrease tends to be smaller as the outside option becomes stronger. For example, The median change in consumer surplus diminishes (in absolute value) from -0.123 when $v_0 = -\infty$ to -0.005 when $v_0 = 0$, and the median change in total welfare diminishes from -0.038 when $v_0 = -\infty$ to -0.008 when $v_0 = 0$.

These results show that consumers are harmed by switching costs. And even when firms benefit from switching costs, consumers' losses more than offset firms' gains and result in a reduction in total welfare. Therefore, these results give support to public policies that aim at reducing switching costs. In the case with a viable outside option, both firms and consumers will benefit from a reduction in switching costs. If the outside option is fairly inferior, however, consumer advocates and industry lobbyists are likely to be on opposing sides of a policy debate, with the former in favor of reducing switching costs and the latter against it.

³Note that Tables A3 and A4 report on the actual changes in consumer surplus and total welfare rather than the percentage changes, as the latter are not invariant to normalization of the intrinsic qualities of the goods.

(1) Firm 1's policy function

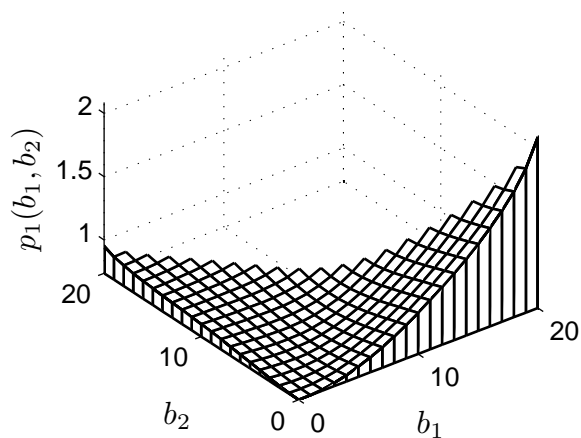

(2) Firm 1's value function

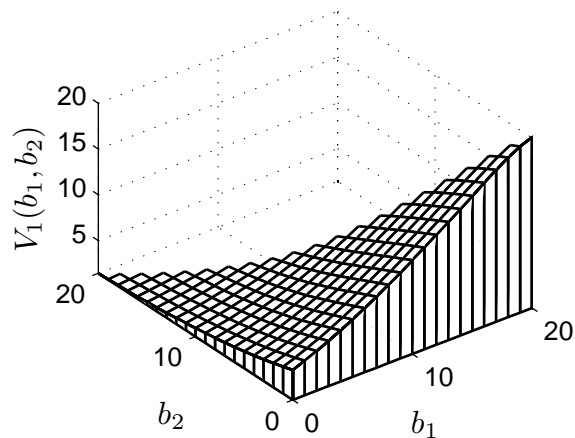

(3) Transient distribution after 15 periods

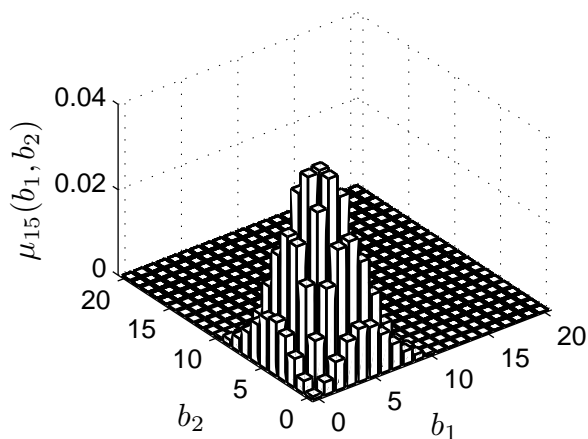

(4) Limiting distribution

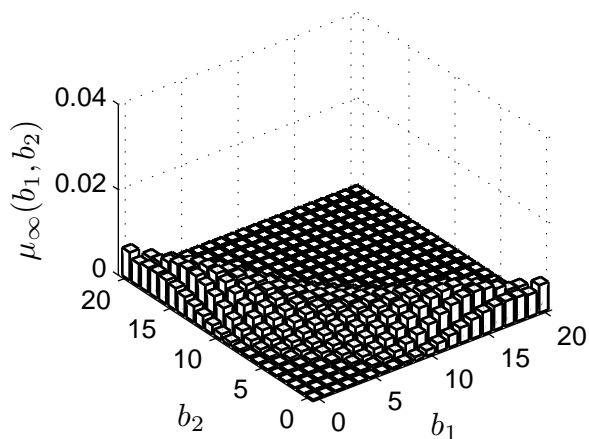

(5) Probability that firm 1 makes a sale

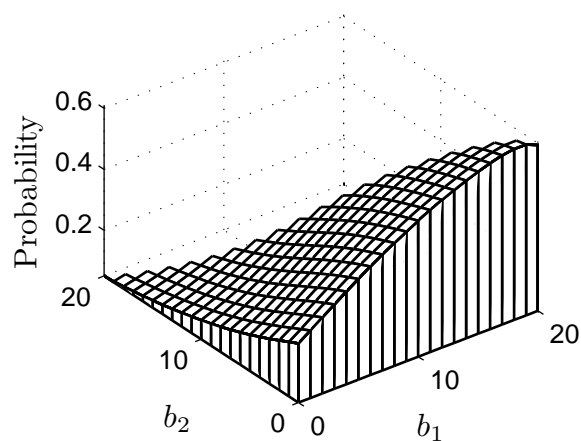

(6) Resultant forces

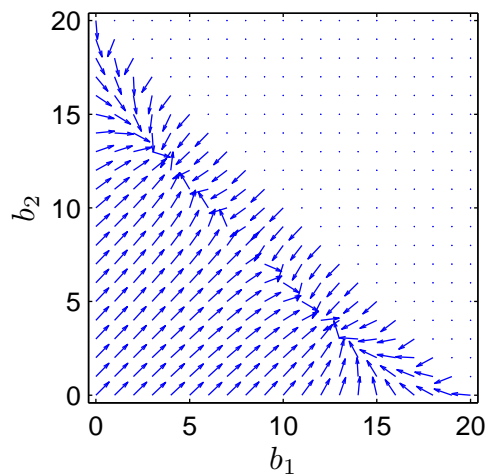

Figure A1. Mild Tipping equilibrium: $v_0 = 0$, $\delta = 0.04$, $\theta = 2.6$, $k = 1$

Table A1. Percentage change in average price from $k = k^0$ to $k = k^0 + 0.2$
 $\delta \in [0.04, 0.1], k^0 \in [0, 3)$

	Percentiles					% negative
	5th	25th	50th	75th	95th	
$v_0 = -\infty, \theta \in [0, 4]$	-1.93%	2.83%	4.77%	6.98%	12.95%	10.1%
$v_0 = -2, \theta \in [0, 4]$	-1.75%	0.18%	0.86%	2.00%	3.43%	20.7%
$v_0 = 0, \theta \in [0, 4]$	-0.92%	-0.24%	-0.02%	0.09%	0.95%	62.0%
$v_0 = -\infty, \theta \in [0, 1)$	-1.94%	2.43%	4.72%	6.73%	11.96%	13.3%
$v_0 = -\infty, \theta \in [1, 2)$	-2.29%	2.71%	5.24%	7.62%	14.70%	12.8%
$v_0 = -\infty, \theta \in [2, 3)$	-1.72%	3.19%	5.27%	7.50%	14.71%	8.2%
$v_0 = -\infty, \theta \in [3, 4]$	-1.15%	2.83%	4.06%	6.13%	10.47%	6.7%
$v_0 = -2, \theta \in [0, 1)$	-1.82%	-0.36%	0.20%	0.46%	1.05%	33.3%
$v_0 = -2, \theta \in [1, 2)$	-2.03%	0.04%	0.57%	1.25%	2.93%	24.4%
$v_0 = -2, \theta \in [2, 3)$	-1.75%	0.69%	1.43%	2.57%	3.87%	14.5%
$v_0 = -2, \theta \in [3, 4]$	-1.47%	1.15%	1.93%	2.63%	3.67%	12.4%
$v_0 = 0, \theta \in [0, 1)$	-0.70%	-0.27%	-0.08%	-0.02%	0.00%	93.7%
$v_0 = 0, \theta \in [1, 2)$	-0.91%	-0.31%	-0.06%	-0.01%	0.10%	78.7%
$v_0 = 0, \theta \in [2, 3)$	-1.07%	-0.26%	-0.01%	0.12%	0.92%	55.4%
$v_0 = 0, \theta \in [3, 4]$	-0.99%	-0.02%	0.18%	0.56%	2.08%	27.0%

Table A2. Percentage change in producer surplus from $k = k^0$ to $k = k^0 + 0.2$
 $\delta \in [0.04, 0.1], k^0 \in [0, 3)$

	Percentiles					% negative
	5th	25th	50th	75th	95th	
$v_0 = -\infty, \theta \in [0, 4]$	-1.93%	2.83%	4.77%	6.98%	12.95%	10.1%
$v_0 = -2, \theta \in [0, 4]$	-2.26%	-0.36%	0.31%	1.34%	2.59%	38.2%
$v_0 = 0, \theta \in [0, 4]$	-2.09%	-1.01%	-0.43%	-0.18%	0.19%	92.5%
$v_0 = -\infty, \theta \in [0, 1)$	-1.94%	2.43%	4.72%	6.73%	11.96%	13.3%
$v_0 = -\infty, \theta \in [1, 2)$	-2.29%	2.71%	5.24%	7.62%	14.70%	12.8%
$v_0 = -\infty, \theta \in [2, 3)$	-1.72%	3.19%	5.27%	7.50%	14.71%	8.2%
$v_0 = -\infty, \theta \in [3, 4]$	-1.15%	2.83%	4.06%	6.13%	10.47%	6.7%
$v_0 = -2, \theta \in [0, 1)$	-2.52%	-1.10%	-0.29%	-0.06%	0.12%	86.1%
$v_0 = -2, \theta \in [1, 2)$	-2.43%	-0.61%	0.12%	0.47%	1.66%	39.2%
$v_0 = -2, \theta \in [2, 3)$	-2.09%	0.31%	0.87%	1.74%	2.78%	18.5%
$v_0 = -2, \theta \in [3, 4]$	-1.60%	0.73%	1.37%	2.03%	3.04%	14.0%
$v_0 = 0, \theta \in [0, 1)$	-2.07%	-1.07%	-0.54%	-0.26%	-0.13%	100.0%
$v_0 = 0, \theta \in [1, 2)$	-2.45%	-1.21%	-0.59%	-0.28%	-0.15%	100.0%
$v_0 = 0, \theta \in [2, 3)$	-2.29%	-1.11%	-0.48%	-0.20%	0.10%	93.5%
$v_0 = 0, \theta \in [3, 4]$	-1.72%	-0.62%	-0.18%	-0.04%	0.99%	79.2%

Table A3. Change in consumer surplus from $k = k^0$ to $k = k^0 + 0.2$
 $\delta \in [0.04, 0.1], k^0 \in [0, 3)$

	Percentiles					% negative
	5th	25th	50th	75th	95th	
$v_0 = -\infty, \theta \in [0, 4]$	-0.378	-0.222	-0.123	-0.082	-0.026	99.0%
$v_0 = -2, \theta \in [0, 4]$	-0.076	-0.047	-0.027	-0.016	-0.007	99.9%
$v_0 = 0, \theta \in [0, 4]$	-0.024	-0.009	-0.005	-0.002	-0.001	100.0%
$v_0 = -\infty, \theta \in [0, 1)$	-0.388	-0.246	-0.129	-0.081	-0.031	100.0%
$v_0 = -\infty, \theta \in [1, 2)$	-0.412	-0.249	-0.129	-0.081	-0.025	100.0%
$v_0 = -\infty, \theta \in [2, 3)$	-0.425	-0.235	-0.124	-0.086	-0.022	99.2%
$v_0 = -\infty, \theta \in [3, 4]$	-0.288	-0.170	-0.114	-0.080	-0.029	97.3%
$v_0 = -2, \theta \in [0, 1)$	-0.036	-0.022	-0.014	-0.010	-0.005	100.0%
$v_0 = -2, \theta \in [1, 2)$	-0.060	-0.034	-0.021	-0.014	-0.008	100.0%
$v_0 = -2, \theta \in [2, 3)$	-0.079	-0.057	-0.033	-0.021	-0.011	100.0%
$v_0 = -2, \theta \in [3, 4]$	-0.084	-0.063	-0.047	-0.033	-0.016	99.7%
$v_0 = 0, \theta \in [0, 1)$	-0.009	-0.004	-0.002	-0.001	-0.001	100.0%
$v_0 = 0, \theta \in [1, 2)$	-0.014	-0.006	-0.003	-0.002	-0.001	100.0%
$v_0 = 0, \theta \in [2, 3)$	-0.025	-0.010	-0.005	-0.003	-0.001	100.0%
$v_0 = 0, \theta \in [3, 4]$	-0.035	-0.016	-0.009	-0.005	-0.002	100.0%

Table A4. Change in total welfare from $k = k^0$ to $k = k^0 + 0.2$
 $\delta \in [0.04, 0.1], k^0 \in [0, 3)$

	Percentiles					% negative
	5th	25th	50th	75th	95th	
$v_0 = -\infty, \theta \in [0, 4]$	-0.089	-0.054	-0.038	-0.024	-0.010	99.8%
$v_0 = -2, \theta \in [0, 4]$	-0.056	-0.037	-0.027	-0.015	-0.007	100.0%
$v_0 = 0, \theta \in [0, 4]$	-0.029	-0.014	-0.008	-0.004	-0.002	100.0%
$v_0 = -\infty, \theta \in [0, 1)$	-0.077	-0.055	-0.040	-0.023	-0.010	100.0%
$v_0 = -\infty, \theta \in [1, 2)$	-0.075	-0.057	-0.041	-0.023	-0.009	100.0%
$v_0 = -\infty, \theta \in [2, 3)$	-0.092	-0.053	-0.040	-0.025	-0.009	99.8%
$v_0 = -\infty, \theta \in [3, 4]$	-0.107	-0.048	-0.032	-0.024	-0.011	99.5%
$v_0 = -2, \theta \in [0, 1)$	-0.058	-0.033	-0.020	-0.011	-0.006	100.0%
$v_0 = -2, \theta \in [1, 2)$	-0.060	-0.038	-0.024	-0.013	-0.007	100.0%
$v_0 = -2, \theta \in [2, 3)$	-0.054	-0.041	-0.028	-0.015	-0.008	100.0%
$v_0 = -2, \theta \in [3, 4]$	-0.051	-0.036	-0.030	-0.023	-0.011	100.0%
$v_0 = 0, \theta \in [0, 1)$	-0.018	-0.009	-0.005	-0.002	-0.001	100.0%
$v_0 = 0, \theta \in [1, 2)$	-0.027	-0.012	-0.006	-0.003	-0.001	100.0%
$v_0 = 0, \theta \in [2, 3)$	-0.034	-0.016	-0.008	-0.004	-0.002	100.0%
$v_0 = 0, \theta \in [3, 4]$	-0.030	-0.019	-0.011	-0.006	-0.003	100.0%